

↑
UP

Haj

Tak dla informacji

–
Beradca
–
Kosztorysant
–
Technik

–
zeba będzie się tym
–
zająć

erm ewa

–
FURÁL

–
METÁLIT

–
DÍPLING

–
BRÜNSCH

RECYCLE & RE-USE

MAGAZINE

Sustainability is the New Normal

[Dr. Christine Lemaitre, CEO of the DGNB, from Schulbau 02-2019]



Sustainability is becoming the new normal — and we want to be part of the solution.

It was from this conviction that the magazine UP! Re-Use was created. We are convinced that metal ceilings can be reused. Even after many years, they still look excellent — simply disposing of them would make little sense. Instead of recycling (metal already has a fully established circular economy), the question becomes: Is re-use possible? We wanted to find out which metal ceilings are particularly suitable for re-use and therefore developed an initial classification system: Platinum, Gold, Silver, or Bronze. First and foremost, we want to convince ourselves and develop a clear sense of when the answer is yes — and when it is no.

Christian Demmelhuber
CEO Fural Metalit Dipling Brünsch

Table of Contents	
2	Editorial
3	Re-Build as a Self-Experiment
4-5	Re-Use in Success Stories
6-7	A Journey Through Time – Where Is Re-Use Possible?
8-9	Ceiling Sails for Re-Use – 10 Years of Ceiling Sails
Possibilities and Assessments for	
10-13	Re-Use – What Is Possible?
14-17	Re-Use Platinum – What Is Re-Use Platinum?
18-21	Re-Use Gold – What Is Re-Use Gold?
22-25	Re-Use Silver – What Is Re-Use Silver?
26-29	Re-Use Bronze – What Is Re-Use Bronze?
Current Topics	
30-31	We Are Proud of Our Projects The Most Beautiful Architecture Innovation – -20% Energy, +20% Acoustics
32-35	Winner of the BFV Award and the Innovation Prize at Messe Bau New – Soft Acoustics at Fural
36-37	Certified Perforations Quotations with CO ₂ and Green Steel
38-39	Material Passport as a Standard with Every Delivery Podcast – 8 Episodes from Circular Economy to Material
40-41	Passports Klimaaktiv – Fural Office Achieves Silver Standard Product of the Year: Baffle and Expanded Metal
Inside Fural	
42-43	10 Examples of Energy and Emissions
44-45	12 Examples of Satisfied Employees
Literature	
46-47	Material Matters, Chapter 5
48-49	Wood – 30–60% Is Burned Immediately
50-51	What Does ESG Mean in Construction? Building Renovation – Taxonomy Compliant?
Genuine Re-Use	
52-53	Company Restaurant in Gmunden
54-55	Fural F1 Office in Gmunden
56-59	Reinstallation of Metal Ceiling Panels
60	Imprint

Re-Build as a Self-Experiment

From the Alpine Hunter Barracks to the Fural F1 Office Building

The company deliberately chose to preserve and repurpose the existing historic building of the Alpine Hunter Barracks, rather than constructing an entirely new building complex. The existing structure was carefully adapted, modernized, and upgraded to meet today's technical and functional requirements.



Re-Use Success Stories

From the Signa Company Restaurant to the Fural Company Restaurant

When an insolvent company no longer needed its kitchen, we seized the opportunity: the entire kitchen equipment was acquired and installed in our company restaurant. Instead of purchasing everything new, we chose reuse. The result: lower costs, less waste — and a fully functional kitchen.



Signa Vienna

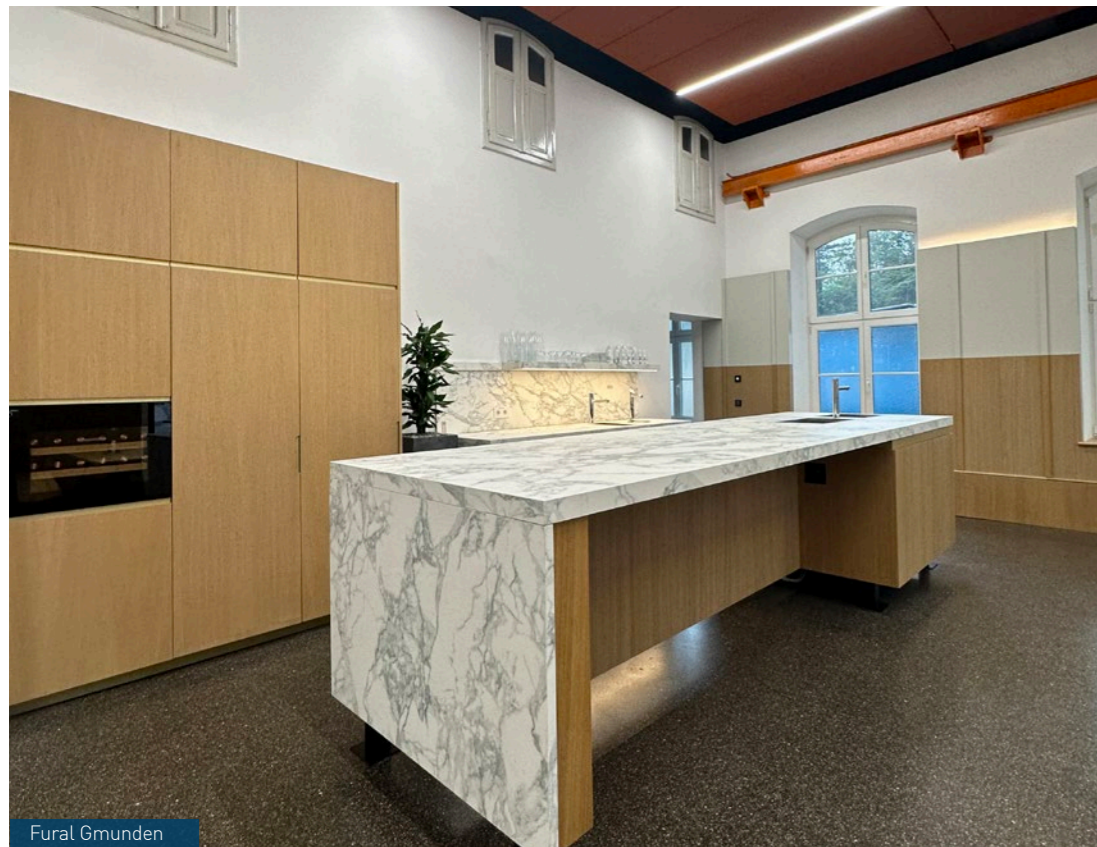

Fural Gmunden

Re-Use Success Stories

From VIAG Glass Partition Walls to Fural Glass Partition Walls

The glass partition walls, formerly used by VIAG Intercom Munich, were reused for the furnishing of our office at Fural Gmunden. In this way, we were able to use materials sustainably, reduce costs, and make optimal use of existing resources — a simple contribution to sustainable working practices.



Glass Partition Walls in Gmunden



Art in the Corridors, Art in the Offices – Art Matters

Re-Use – What is Possible?

Images from Presentations Before the Year 2000
A Journey Through Time – Where is Re-Use Possible?

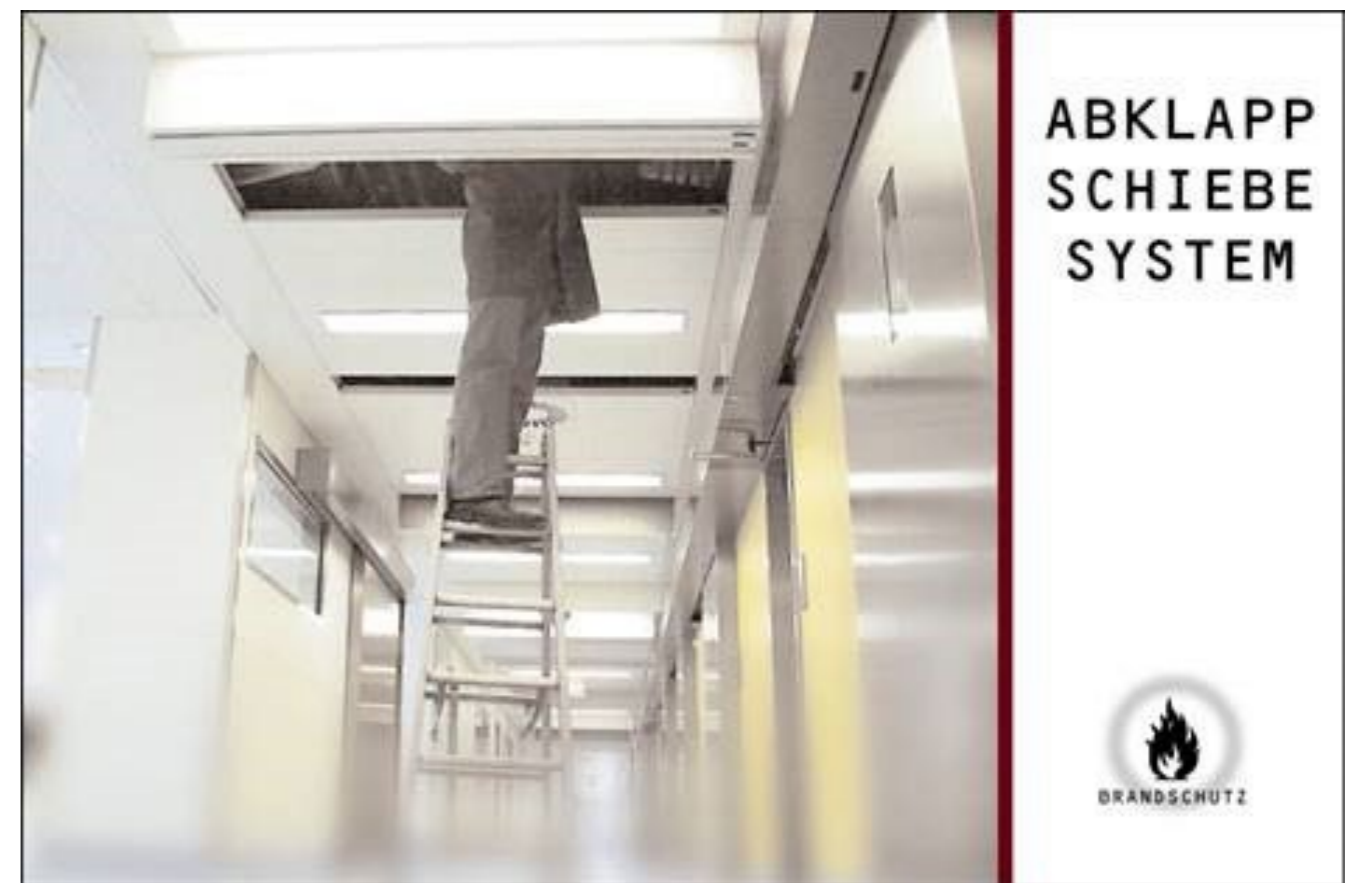
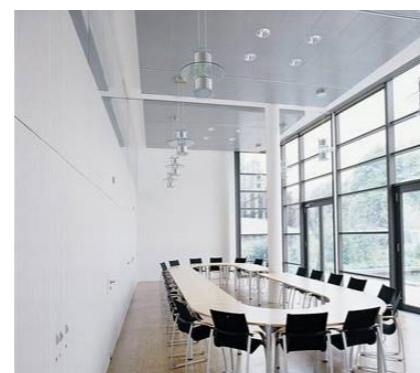
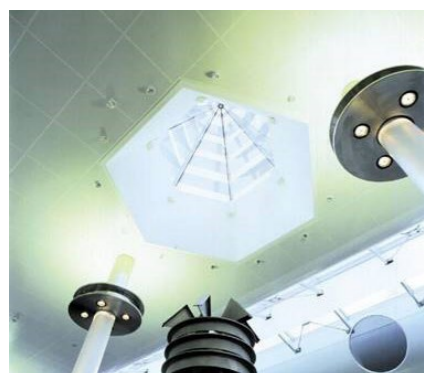

Re-Use – What is Possible?

Floating ceilings in Re-Use – 10 Years of Use

Imagine entering a building 15 years later and still being proud of its ceilings. No water damage, no scratches – instead, high-quality surfaces with functional benefits such as acoustics, cooling, and heating. And unlike in the past: no nicotine stains anymore, thanks to smoking bans.



2015: GOTECH, Weissach (DE)



2016: Emmi Butter Headquarters, Lucerne (CH)



2017: Schuler, Göppingen (DE)

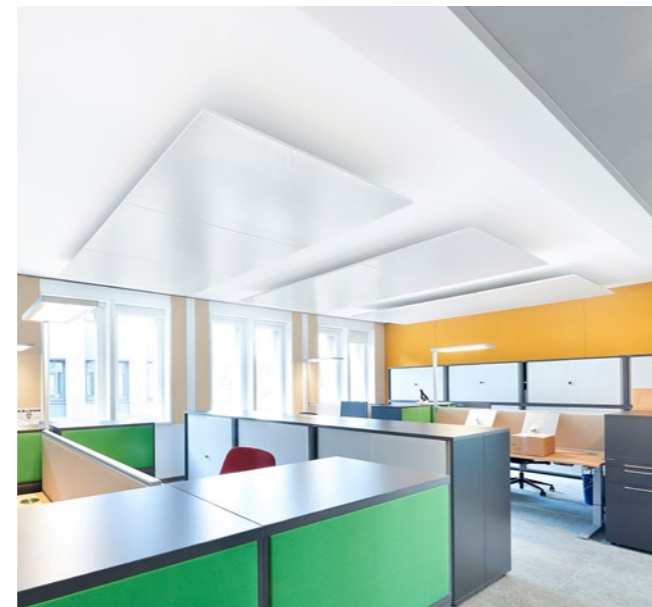

2018: Erber Group, Getzersdorf (AT)



2019: Sandgruben, Basel (CH)



2020: E-Campus, Graz (AT)



2021: Selmoni, Basel (CH)



2022: Legero United Campus, Feldkirchen (AT)

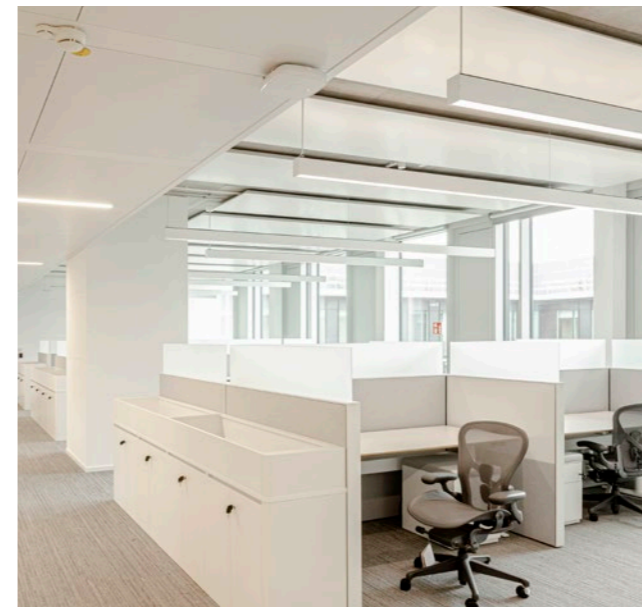

2023: Karlstraße, Munich (DE)

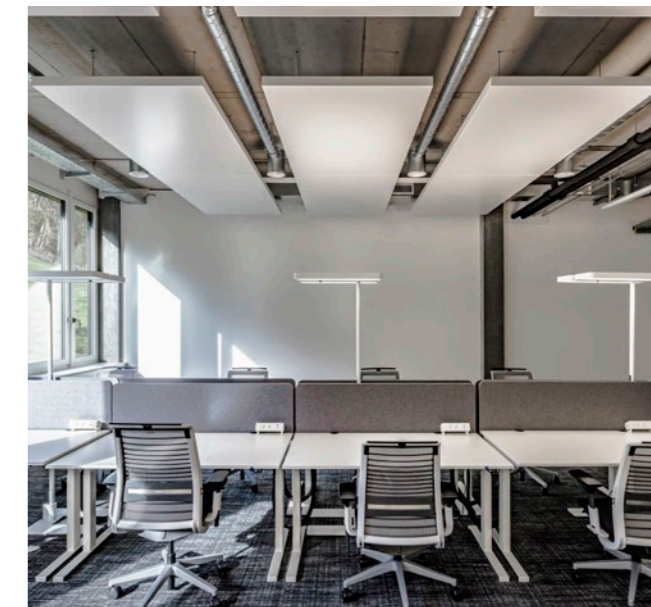

2024: Park Innovaare, Villigen (CH)

Re-Use – What is Possible?

Is a Re-Use Index Possible or Meaningful?

In order to objectively assess the quality and reusability of used metal ceilings, Fural attempted to develop a standardized scoring system. This system takes various properties of the ceiling panels into account and classifies them into four quality categories: **Bronze, Silver, Gold, and Platinum.**

Evaluation Criteria

1. System Type

KLB (chilled beam ceiling):	15 points
KLK (chilled ceiling):	10 points
Wall-mounted system:	5 points
Fire protection ceiling:	5 points

2. Cooling Function (optional)

If available, the cooling performance of a system is included in the total score with a factor of 0.7.

3. Coating

Powder-coated:	15 points
Parzifal:	10 points

4. Color

White:	15 points
RAL 9006 (aluminium):	10 points
NCS colors (special colors):	5 points

5. Length Category

Standard lengths:	15 points
Special lengths:	10 points
Extra-special lengths:	5 points

6. Quantity

More than 500 units:	15 points
More than 300 units:	10 points
Less than 300 units:	5 points

7. Age of the Ceiling Panels





Less than 10 years old:	15 points
More than 10 years old:	10 points

8. Original Building Type

Office buildings:	15 points
Educational buildings:	10 points
Healthcare buildings:	10 points

Classification by Score

Score Re-Use Standard

up to 70 points	Bronze	
71–85 points	Silber	
86–100 points	Gold	
Over 100 points	Platinum	

Example Evaluation

A metal ceiling of the KLB type, white powder-coated, in standard length, with more than 500 units, less than 10 years old, originating from an office building, and without a cooling function achieves:

System type KLB:	15 points
Powder coating:	15 points
White color:	15 points
Standard length:	15 points
Quantity >500:	15 points
Age <10 years:	15 points
Building type Office:	15 points
Total:	105 points

→ Standard: Platinum

Re-Use – What is Possible?

Is a Re-Use Index Possible or Meaningful?

Initial Conclusion of a Re-Use Index:

Advantage: Already at the quotation stage, an evaluation or classification into Platinum, Gold, Silver, or Bronze can be carried out based on defined criteria. This creates a clear focus from the very beginning.

Re-Use Index Using Reference Projects as Examples

YEAR	USE	CONSTRUCTION PROJECT	SYSTEM	COOLING CEILING	COLOUR	AREA (m²)	RE-USE INDEX*	RE-USE ACC. TO INDEX	RE-USE SUBJECTIVE
2015	Health	Apothekerhaus	Brands.	-	RAL 9010	61,42	70,00	Bronze	Bronze
2015	Office	ASR Utrecht	KLB	Yes	RAL 9010	8 021,63	75,00	Silver	Gold
2015	Prod.	Metallbauhalle Schlegel	KLK	-	RAL 9010	236,64	85,00	Silver	Bronze
2015	Office	Bernegger Molln	KLK	-	RAL 9010	1 163,76	95,00	Gold	Bronze
2015	Office	Brehmstraße Wien	KLK	-	RAL 9006	1 203,36	75,00	Silver	Silver
2015	Education	BSZ St. Pölten	KLK	-	RAL 9010	6 379,36	90,00	Gold	Silver
2015	Office	EIB Hannut	KLB	Yes	RAL 9010	38,36	60,00	Bronze	Silver
2015	Office	Fierens, Zellik	KLH	Yes	RAL 9006	594,81	56,00	Bronze	Silver
2015	Office	Jansen Dienstenzentrum	KLB	-	RAL 9010	612,07	100,00	Gold	Gold
2015	Health	LK Neunkirchen	Swing+KLK	-	RAL 9010	15 056,92	85,00	Silver	Silver
2015	Health	LKH Graz	KLH	-	Special/NCS	922,69	80,00	Silver	Bronze
2015	Health	PVA Wien	KQK+KLK	-	RAL 9010	1 782,09	95,00	Gold	Gold
2015	Office	PWC Inteco	KLK+KQK	Yes	RAL 9010	19 084,53	75,00	Silver	Gold
2015	Office	Rolex Novate Milanese	KLK	Yes	RAL 9010	1 005,93	67,50	Bronze	Bronze
2015	Health	SKA St. Radegund	KQK+KLK	-	RAL 9010	11 290,06	95,00	Gold	Gold
2015	Office	Targobank Duisburg	KLB	-	RAL 9010	4 230,29	100,00	Gold	Gold
2015	Office	Targobank Duisburg	KLB	-	RAL 9010	4 230,29	100,00	Gold	Gold
2015	Health	Uniklinik Dresden	Brands.	-	RAL 9010	304,56	85,00	Silver	Silver
2016	Office	AOK, Berlin	KLH	Yes	RAL 9010	4 370,00	67,50	Bronze	Bronze
2016	Office	Dansk Metal Copenhagen	KLK	-	RAL 9010	7 150,20	95,00	Gold	Silver
2016	Office	Emmi Butterzentrale, Luzern	Floating ceil.	Yes	RAL 9010	1 076,10	75,00	Silver	Silver
2016	Office	Erber Group Getzersdorf	Floating ceil.	Yes	RAL 9010	2 682,90	78,75	Silver	Silver
2016	Office	GOTECH Weissach	Floating ceil.	Yes	RAL 9010	285,40	71,25	Silver	Platinum
2016	Health	Herzzentrum Ludwigshafen	KQK+Brands.	-	RAL 9010	1 229,10	90,00	Gold	Bronze
2016	Office	Hotel Atlantis Zürich	Brands.	-	RAL 9010	315,80	95,00	Gold	Bronze
2016	Education	International School DK	KLK	Yes	RAL 9010	23 263,60	71,25	Silver	Silver
2016	Office	The Edge Amsterdam	Floating ceil.	Yes	RAL 9010	28 352,90	78,75	Silver	Platinum
2017	Office	Heinze Sanitär Ainring	KLB	Yes	RAL 9010	4 340,29	73,50	Silver	Silver
2017	Education	Schule am Hedernfeld	KLK	-	RAL 9010	715,78	90,00	Gold	Silver
2017	Education	Schule Tumblingerstraße Mü	wall cl.	-	RAL 9010	917,16	90,00	Gold	Silver
2017	Office	Schuler Göppingen	KLK	Yes	RAL 9010	6 621,49	75,00	Silver	Gold
2017	Office	Schuler Göppingen	KLK	-	RAL 9010	494,94	100,00	Gold	Gold
2017	Office	Schunk Hoffmann	KLK	-	RAL 9010	385,97	100,00	Gold	Silver
2017	Health	Spital Linde Biel CH	Brands.	-	RAL 9010	272,24	90,00	Gold	Silver
2017	Education	Uni Karl Landstein Krems	KLK	-	Special/NCS	766,77	85,00	Silver	Gold
2017	Office	Vector Stuttgart	KLB	Yes	RAL 9010	13 402,08	94,50	Gold	Gold
2017	Office	Vector Stuttgart	KLB	-	RAL 9010	191,90	105,00	Platinum	Gold
2018	Office	Gemeentehois Westland	KLH+KLBF	Yes	RAL 9010	6 867,60	75,00	Silver	Gold
2018	Office	Gemeentehois Wijchen	KLBF	-	RAL 9010	2 347,40	100,00	Gold	Gold
2017	Education	Hoogeschool Rotterdam	KLB+KLgG	-	RAL 9010	3 729,60	100,00	Gold	Gold
2018	Office	Swarovski Manufaktur	KLK	-	RAL 9010	4 786,62	95,00	Gold	Gold
2018	Health	SKL Lüneburg	Brands+Swing	-	RAL 9010	2 715,31	90,00	Gold	Gold
2018	Project	Parndorf Fashion Outlet	KQK	-	Special/NCS	217,06	80,00	Silver	Bronze
2018	Education	Oberstufenschulhaus Horw	KLH	-	RAL 9010	6 355,35	95,00	Gold	Gold
2018	Health	LK Mödling	KQK	-	RAL 9010	386,62	100,00	Gold	Silver
2018	Project	Hotel Bristol Bern	KLE	-	Special/NCS	595,58	80,00	Silver	Silver

Re-Use Platinum or Gold or Silver or Bronze...

Pages 14 to 29 contain older references and reference images from Fural. Our objective is to identify re-use opportunities and to assess them according to the categories Re-Use Platinum, Gold, Silver, or Bronze. All projects are still actively in operation. All projects (hopefully) still maintain perfect form, function, and appearance. None of these projects have actually been offered to us for re-use. Our focus is purely on evaluating the potential for re-use or the possible "harvesting" of reusable materials.



Re-Use Platinum: 100% Re-Use of Ceilings and Additional Elements such as Floating Ceilings + Lighting
All types of mono floating ceilings
No perimeter connections



Re-Use Gold: >90% Suitable for Re-Use
Many similar sizes, standard dimensions such as 625 x 625 or 600 x 1200 mm
Few cut panels, minimal losses due to perimeter connections

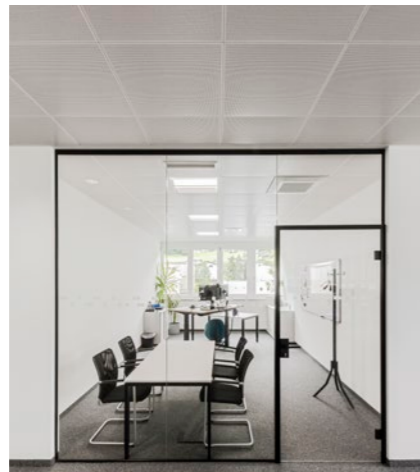

Re-Use Silver: >70% Suitable for Re-Use
Many office ceilings – in combination with new ceiling planning / grid layouts
Cut panels used as perimeter connections, resulting in losses at the edges

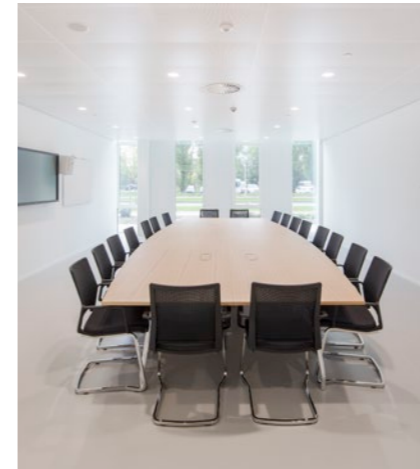

Re-Use Bronze: <70 % Re-Use
Special metal ceilings
Many different colors

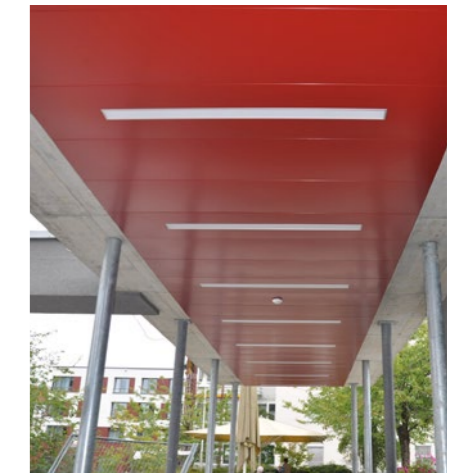
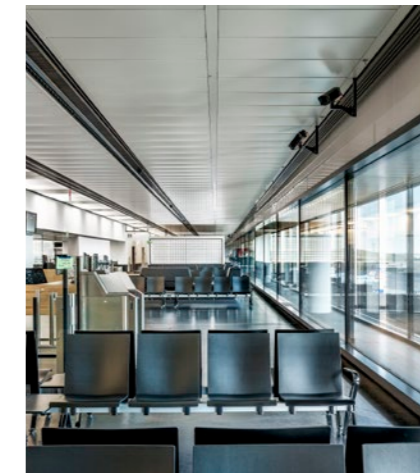

Re-Cycling Only Circular Economy – A Practice Already Implemented 100% in the Metals Industry

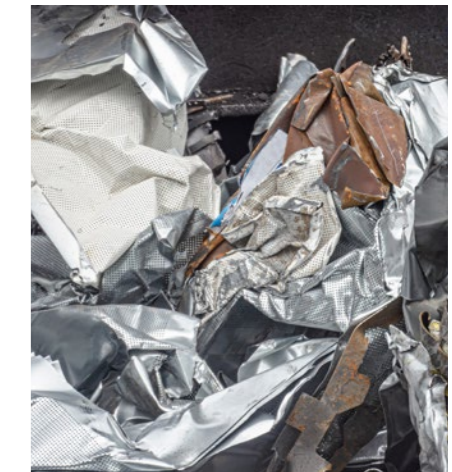

GOTECH, Weissach – Bronze or Platinum?



“Bronze” in the index evaluation,
“Platinum” in the subjective evaluation.

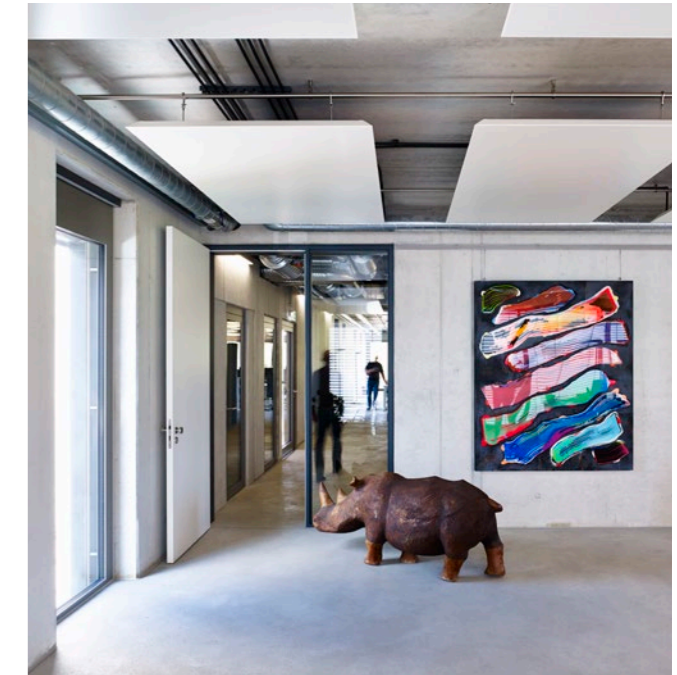
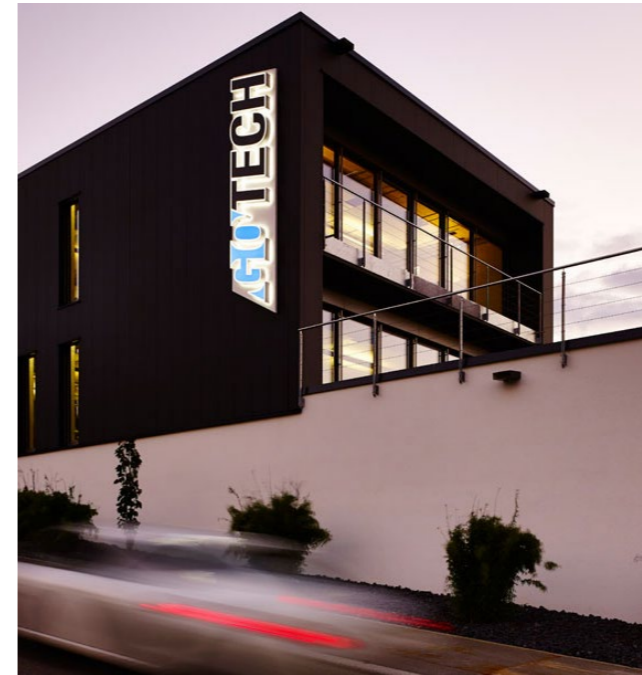

Re-Use – Quantity, Dimensions, Designation – The Most Frequently Delivered Materials

Quantity	Unit	Designation
47	pcs.	KLS 3000 × 1200 mm × 1200 / 45 0.7 mm –, black fleece inserts – assorted, 2516, color 9010
22	pcs.	KLS 2400 × 1200 mm × 1200 / 45 0.7 mm –, black fleece inserts – assorted, 2516, color 9010
12	pcs.	KLS 3000 × 1000 mm × 1000 0.7 mm –, black fleece inserts – assorted, 2516, color 9010
7	pcs.	KLS 2000 × 1200 mm × 1200 / 45 0.7 mm –, black fleece inserts – assorted, 2516, color 9010

Quantity	Unit	Designation
47	pcs.	KLS3000x1200 45

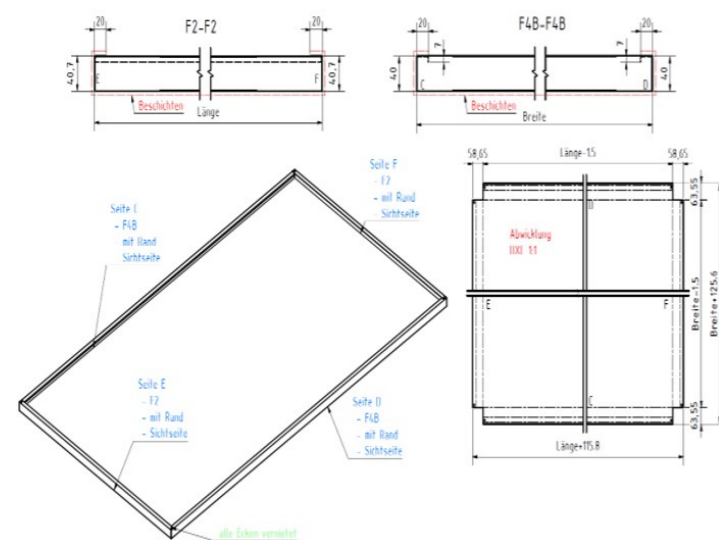

Index Evaluation

Floating ceiling system type: 15 points
Powder coating: 15 points
White color: 15 points
Standard length: 15 points
Quantity <300: 5 points
Age <10 years: 15 points
Building type Office: 15 points
Cooling ceiling: YES Factor 0.75
Total: 71.25 points

→ Standard: Bronze

Facts

- **Ceiling system:** Use of precisely manufactured chilled floating ceilings as a central architectural and technical design element
- **Function:** Control of room acoustics and temperature regulation through large-format chilled floating ceilings
- **Dimensions of the floating ceilings:** 3,000 × 1,200 mm | 2,400 × 1,200 mm
- **Perforation:** Rg 2.5 – 16%
- **Surface finish:** RAL 9010, pure white
- **Design:** 45° folded edges creating a flat, floating appearance of the ceiling elements

Subjective Evaluation

Simply beautiful ceilings. All floating ceilings, including the lighting, can be reused. With floating ceilings, no dirt is rubbed onto the surface through air movement. Even after 25 years, this type of ceiling still looks like new. Floating ceilings and luminaires mean >100% can be reused, which for me clearly deserves a Platinum rating.

→ Standard: Platinum

Christian Demmelhuber,
CEO Fural Group



Floating ceilings are ideal re-use products because they are not bound to a ceiling grid, can be freely positioned, and even after many years are far from becoming scrap metal, but can instead be reused without difficulty. For me, they are the ultimate re-use product – therefore Platinum.

→ Standard: Platinum

Steffen Wand,
Tech. Consultant and Branch
Manager Dipling Werk



The floating ceilings are of high quality and are fundamentally very well suited for re-use. However, the integrated cooling technology somewhat limits their reusability, as reuse is only possible with additional adaptation effort.

→ Standard: Bronze

Martin Richter, Innovation
and Product Management



Vector Informatik, Stuttgart Platinum



“Platinum” in the index evaluation,
“Platinum” in the subjective evaluation.

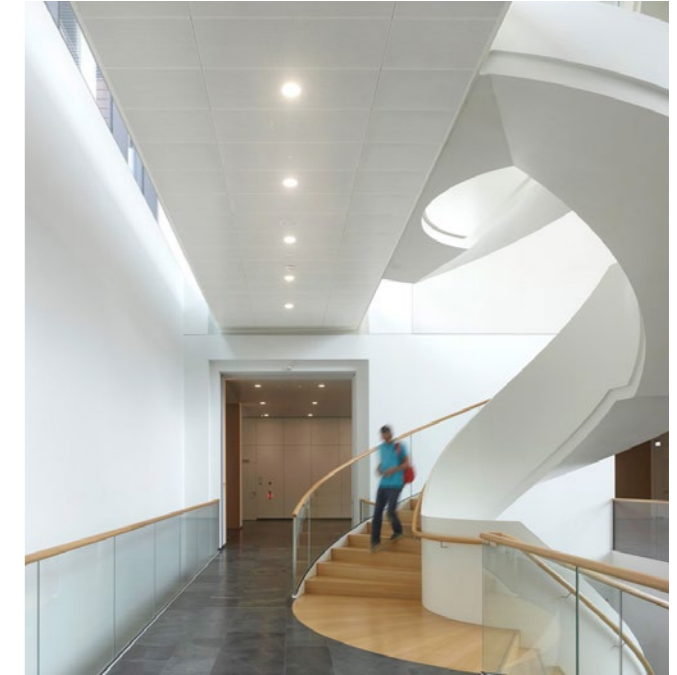

Re-Use – Quantity, Dimensions, Designation – The Most Frequently Delivered Materials

Quantity	Unit	Designation
5248	pcs.	KLB 1469 × 474 mm /474 P3_BR 0.7 mm –, black fleece inserts – assorted, 2516, color 9010
2755	pcs.	KLB 1469 × 491 mm /491 P1_BR 0.7 mm –, black fleece inserts – assorted, 2516, color 9010
524	pcs.	KLBG 1390 × 474 mm P6_BR-Z 0.7 mm –, black fleece inserts – assorted, 2516, color 9010
431	pcs.	KLK 2395 × 530 mm Pi52_Z 0.6 mm –, black fleece inserts – assorted, 2516, color 9010
410	pcs.	KLK 2650 × 530 mm Pi43_Z 0.6 mm –, black fleece inserts – assorted, 2516, color 9010
354	pcs.	KLBG 1465 × 474 mm P10_BR-Z 0.7 mm –, black fleece inserts – assorted, 2516, color 9010

Quantity	Unit	Designation
5248	pcs.	KLB 1469/474 P3_BR

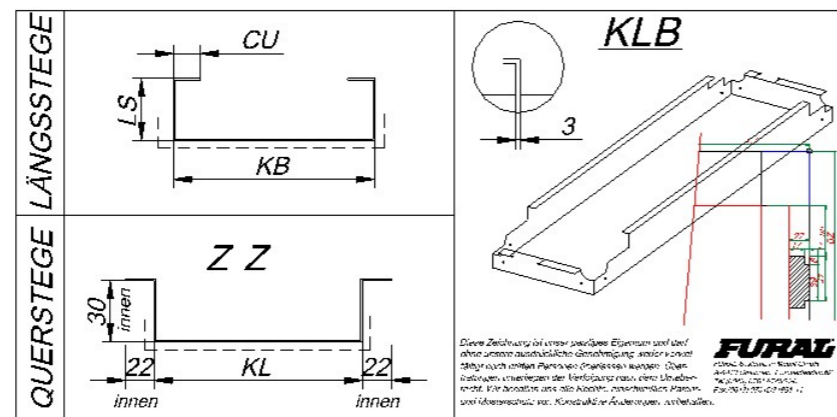

Index Evaluation

Strip grid system type: 15 points
Powder coating: 15 points
White color: 15 points
Standard length: 15 points
Quantity >500: 15 points
Age <10 years: 15 points
Building type Office: 15 points
Chilled ceiling: NO Factor 1.00
Total: 105 points

→ **Standard: Platinum**

Facts

- **Ceiling system:** Strip grid ceilings, hang-in ceilings, or corridor ceilings – popular systems in standard sizes
- **Function:** Acoustics, accessibility for maintenance, partly with cooling function
- **Dimensions of the panels:** 1,469 × 474 mm | 1,469 × 491 mm | 2,395 × 530 mm
- **Perforation:** Rg 2.5 – 16%
- **Surface finish:** RAL 9010, pure white
- **Design:** 45° folded edges creating a flat, floating appearance of the ceiling elements

Subjective Evaluation

At Vector, thousands of square meters of ceilings have been installed – in standard sizes and colors, perfectly designed for reusability – practical, efficient, and without special custom solutions.

→ **Standard: Platinum**

Dirk Freytag,
CTO Fural Group



What makes this ceiling system convincing is its practicality in everyday use: standard sizes and neutral colors. In a project like Vector, where enormous ceiling areas were installed, this is exactly what makes the difference. It is no surprise that the project received a Platinum rating.

→ **Standard: Platinum**

Thomas Pelikan,
CTO Fural Group



These ceilings simply work – standard dimensions, subtle colors, and suitable for use almost anywhere. With such large surface areas as in the Vector project, this becomes a real advantage for re-use. It is clear why the project scores highly in terms of reusability.

→ **Standard: Platinum**

Perrine Rapp,
Branch Manager Metalit



A.S.R. Utrecht Gold



“Silver” in the index evaluation,
“Gold” in the subjective evaluation.



Re-Use – Quantity, Dimensions, Designation – The Most Frequently Delivered Materials

Quantity	Unit	Designation
6543	pcs.	KLB 1700 × 520.4 mm 0.7 mm –, 2516, color 9010
810	pcs.	KLB 2400 × 400 mm 0.7 mm –, 2516, color 9010
664	pcs.	KLB 1700 × 500.4 mm 0.7 mm –, 2516, color 9010
458	pcs.	KLB 1700 × 550.4 mm 0.7 mm –, 2516, color 9010
178	pcs.	KLB 1700 × 470.4 mm 0.7 mm –, 2516, color 9010
96	pcs.	KLB 1700 × 550.4 mm 0.7 mm –, 2516, color 9010

Quantity	Unit	Designation
5145	pcs.	KLB 520,4x1700

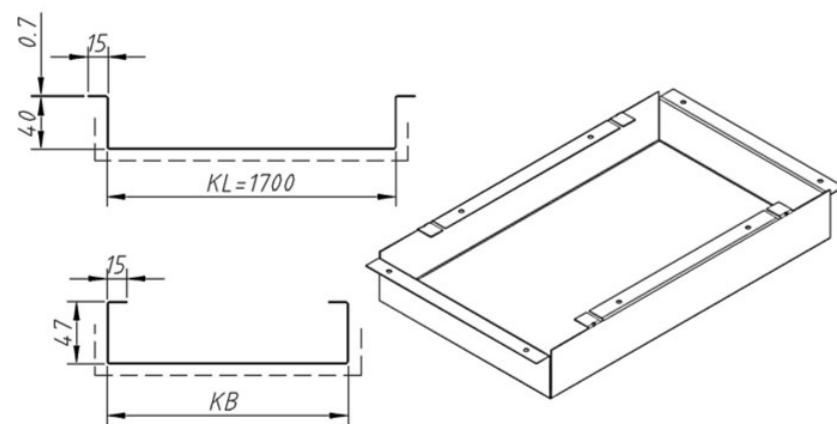

Index Evaluation

Strip grid system type: 15 points
Powder coating: 15 points
White color: 15 points
Standard length: 15 points
Quantity >500: 15 points
Age <10 years: 15 points
Building type Office: 15 points
Cooling ceiling: YES Factor 0.75
Total: 75 points

→ **Standard: Silver**

Facts

- **Ceiling system:** Strip grid ceilings – popular systems in standard sizes
- **Function:** Acoustics, accessibility for maintenance
- **Dimensions of the panels:** 1,700 × 520.4 mm | 2,400 × 400 mm | 1,700 × 500.4 mm | 1,700 × 550.4 mm | 1,700 × 470.4 mm
- **Perforation:** Rg 2.5 – 16%
- **Surface finish:** RAL 9010, pure white

Subjective Evaluation

The installed FURAL metal ceilings are exceptionally well suited for future reuse. The panel dimensions follow standard formats, and the color selection in RAL 9010 and RAL 8022 was deliberately kept neutral – ideal conditions for flexible reuse in other projects.

→ **Standard: Gold**

Herbert Brunmeier,
Technical Consulting



With more than 17,500 m², the large-scale strip grid ceilings offer significant potential for re-use. The installed system not only provides effective acoustic performance, but is also fully accessible for maintenance – an important prerequisite for clean dismantling and material-specific reuse.

→ **Standard: Gold**

Robert Markowski,
Technical Consulting



The extensive ceiling areas with many uniformly sized panels and a subtle color scheme create ideal conditions for reuse. The demountable system and high-quality execution enable clean dismantling and versatile secondary use.

→ **Standard: Gold**

Martin Richter, Innovation
and Product Management



Jansen Dienstzentrum Gold



“Gold” in the index evaluation,
“Gold” in the subjective evaluation.

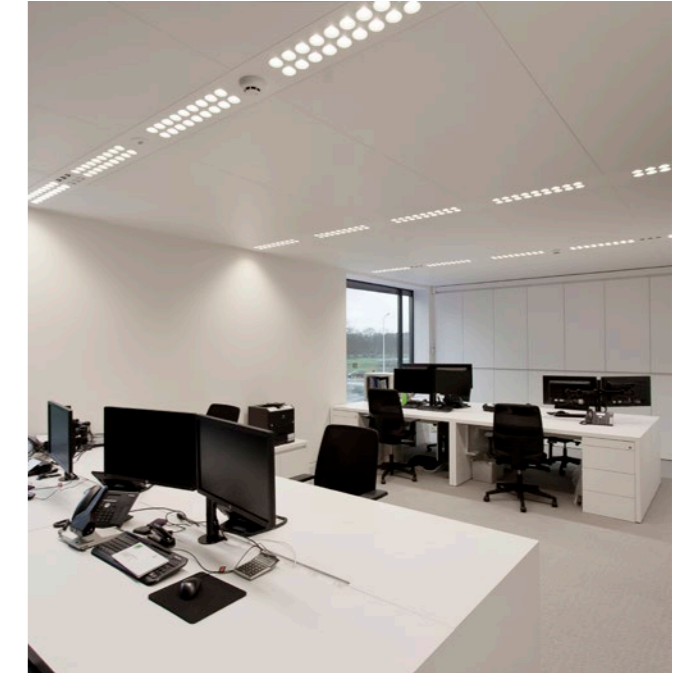

Re-Use – Quantity, Dimensions, Designation – The Most Frequently Delivered Materials

Quantity	Unit	Designation
213	pcs.	KLS 1800 × 900 mm 0.7 mm steel, black fleece inserts – assorted, 0704 g, color 9010
44	pcs.	KLBF 1760 × 904 mm 0.7 mm –, black fleece inserts – assorted, 704, color 9010A
33	pcs.	KLS 2500 × 855 mm 0.7 mm –, black fleece inserts – assorted, 704, color 9010A
33	pcs.	KLBF 2205 × 904 mm 0.7 mm –, black fleece inserts – assorted, 704, color 9010A
12	pcs.	JSC01 1800 × 900 mm 0.7 mm, acoustic fleece R% FF KD2584 black, 0704 g, color RAL 6005
10	pcs.	JSC04 1800 × 900 mm 0.7 mm, acoustic fleece R% FF KD2584 black, 0704 g, color RAL 6005

Quantity	Unit	Designation
12	pcs.	JCS01 900x1800

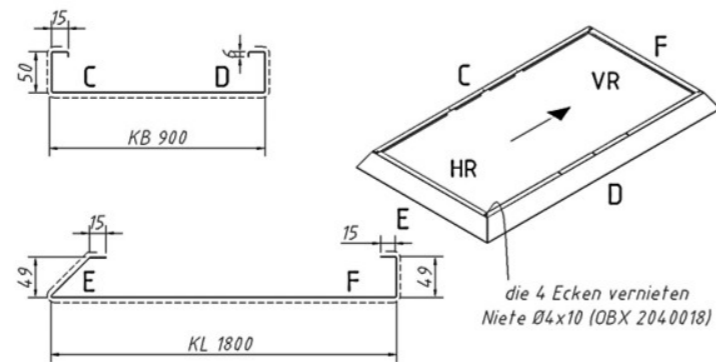
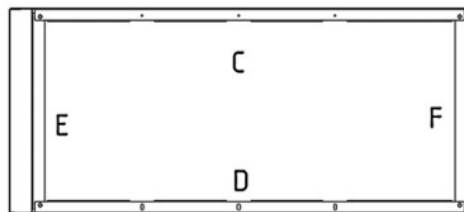

Index Evaluation

Strip grid system type: 15 points
Powder coating: 15 points
White color: 15 points
Standard length: 15 points
Quantity >500: 15 points
Age >10 years: 10 points
Building type Office: 15 points
Cooling ceiling: NO Factor 1.0
Total: 100 points

→ **Standard: Gold**

Facts

- **Ceiling system:** Strip grid ceilings – popular systems in standard sizes
- **Function:** Acoustics
- **Dimensions of the panels:** 1,800 × 900 mm | 1,760 × 904 mm | 2,205 × 904 mm
- **Perforation:** Rg 0.7 – 4%
- **Surface finish:** RAL 9010, pure white

Subjective Evaluation

The metal ceilings in the Jansen Service Center are a strong example of how functional architecture and future-oriented material selection can be successfully combined. The installed strip grid ceilings in neutral RAL 9010 not only provide effective acoustic performance, but are also ideally suited for future reuse thanks to their standardized formats and dimensions.

→ **Standard: Gold**

Tobias Todt,
Auth. Signatory Brunsch



The ceiling areas are large and clearly structured, while the panel dimensions follow common grid sizes – significantly simplifying dismantling, sorting, and re-use.

→ **Standard: Gold**

Andreas Fürthauer,
Auth. Signatory



At the Jansen Service Center, a proven strip grid system was used – featuring large-format panels, neutral colors, and a classic RAL surface finish. This not only creates a calm ceiling appearance with strong acoustic performance, but also provides ideal conditions for future reuse.

→ **Standard: Gold**

Flavio Kunz,
Sales Manager

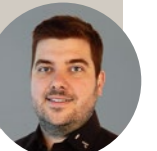

Emmi Butterzentrale Silver



“Silver” in the index evaluation,
“Silver” in the subjective evaluation.

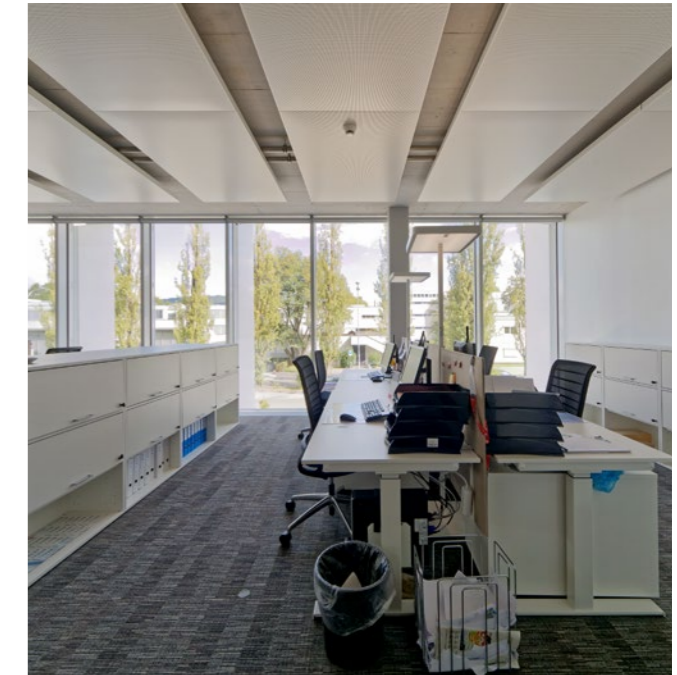

Re-Use – Quantity, Dimensions, Designation – The Most Frequently Delivered Materials

Quantity	Unit	Designation
139	pcs.	KLS 2700 x 1050 mm 0,7 mm Steel
139	pcs.	375F 1875 x 1050 mm 0,7 mm
139	pcs.	375K 1875 x 1050 mm 0,7 mm
16	pcs.	523F 2615 x 1050 mm 0,7 mm
16	pcs.	523K 2615 x 1050 mm 0,7 mm
12	pcs.	240 2400 x 1030 mm 0,7 mm

Quantity	Unit	Designation
139	pcs.	KLS 2700x1050

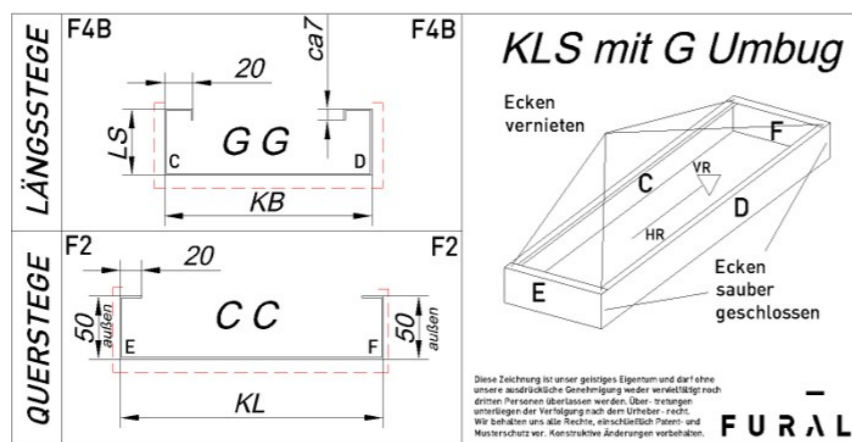

Index Evaluation

Floating ceiling system type: 15 points
Powder coating: 15 points
White color: 15 points
Standard length: 15 points
Quantity <500: 10 points
Age <10 years: 15 points
Building type Office: 15 points
Chilled ceiling: YES Factor 0.75
Total: 75 points

→ **Standard: Silver**

Facts

- **Ceiling system:** Floating ceilings – popular systems in standard sizes
- **Function:** Acoustics, cooling
- **Dimensions of the panels:** 1,800 × 900 mm | 1,760 × 904 mm | 2,205 × 904 mm
- **Perforation:** Rg 2.5 – 16%
- **Surface finish:** RAL 9010, pure white
- **Area:** 980 m²

Subjective Evaluation

My opinion on cooling ceilings is different. In my view, cooling ceilings are fully suitable for re-use. There are no perimeter connections, the luminaires can also be reused, and all floating ceiling elements are ideal for re-use. My conclusion is therefore Platinum.

→ **Standard: Platinum**

Christian Demmelhuber,
CEO Fural Group



The neutral surface finish in RAL 9010 integrates discreetly into the architecture and allows for flexible future reuse. The large overall area – totaling 980 m² – together with the standardized panel dimensions also enables easy dismantling and reuse.

→ **Standard: Gold**

Martin Richter, Innovation
and Product Management



980 m² of floating ceilings with cooling function, standard panel formats, and neutral colors – ideal for dismantling and reuse. Functionally strong and architecturally flexible. If it were not for the cooling coils, which would most likely need to be replaced, the project would have been a candidate for a Gold rating.

→ **Standard: Silver**

Perrine Rapp,
Branch Manager Metalit



CIS, Copenhagen Silver



“Silver” in the index evaluation,
“Silver” in the subjective evaluation.

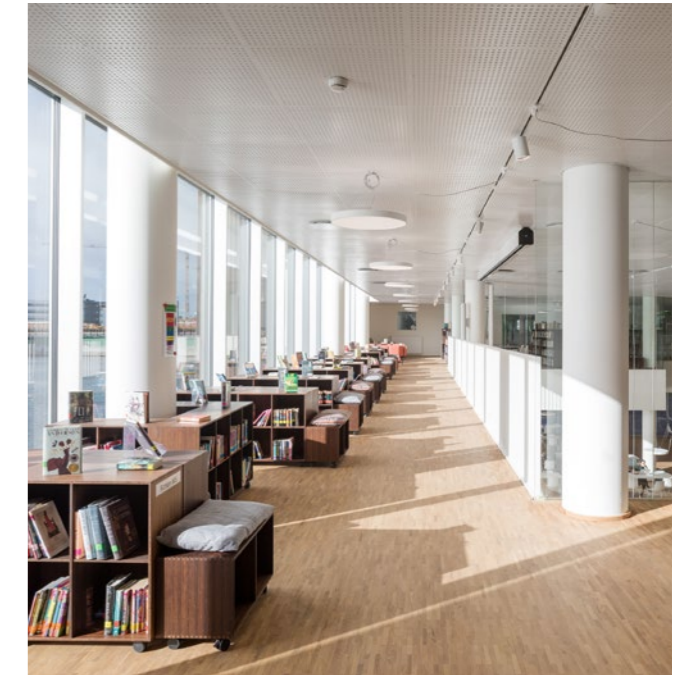

Re-Use – Quantity, Dimensions, Designation – The Most Frequently Delivered Materials

Quantity	Unit	Designation
22147	pcs.	KLK 720 × 720 mm × 720 0.6 mm -, white fleece inserts, 2516, color 9016
7426	pcs.	KLK 720 × 720 mm × 720 0.6 mm -, white fleece inserts, 1423, color 9016
4110	pcs.	KLK 688 × 720 mm × 720 0.6 mm -, white fleece inserts, 2516, color 9016
2000	pcs.	KLK 720 × 720 mm 0.6 mm -, white fleece inserts, 2516, color 9016
1430	pcs.	KLK 720 × 720 mm × 720 0.6 mm steel, white fleece inserts, 2516, color 9016
810	pcs.	KLK 720 × 720 mm × 720 0.6 mm steel, white fleece inserts, 1423, color 9016

Quantity	Unit	Designation
25577	pcs.	KLK 720x720

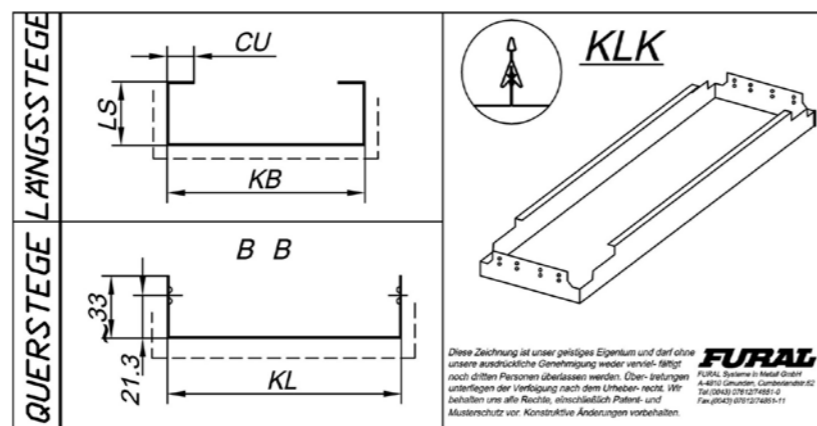

Index Evaluation

Clip-in system: 10 points
Powder coating: 15 points
White color: 15 points
Standard length: 15 points
Quantity >500: 15 points
Age <10 years: 15 points
Building type Education: 10 points
Cooling ceiling: YES Factor 0.75
Total: 71.25 points

→ **Standard: Silver**

Facts

- **Ceiling system:** Clip-in system – long-panel cassettes
- **Function:** Acoustics, cooling
- **Dimensions of the panels:** 720 × 720 mm | 688 × 720 mm
- **Perforation:** Rg 2.5 – 16% | Rg 1.4 – 23%
- **Surface finish:** RAL 9016, traffic white
- **Area:** 22,100 m²

Subjective Evaluation

The metal ceiling areas are large-scale, feature neutral colors, and use standardized panel dimensions – ideal conditions for future re-use. Thanks to the clip-in system, the ceiling panels can be easily dismantled, inspected, and potentially reinstalled in another location.

→ **Standard: Silver**

Christian Demmelhuber,
CEO Fural Group



With its modular ceiling elements and clearly defined grid dimensions, the system fulfills important criteria for re-use. The understated white design, combined with easy accessibility, makes the ceiling installation at the Copenhagen International School a strong candidate for future reuse.

→ **Standard: Silver**

Herbert Brunmeier,
Technical Consulting



This project is an excellent example of how high-quality metal ceiling systems not only deliver strong architectural and functional performance, but also provide ideal conditions for re-use through their standardized panel formats, thereby making an important contribution to resource conservation and a truly circular economy.

→ **Standard: Silver**

Steffen Wand,
Tech. Consultant and Branch
Manager Dipling Werk



AOK, Berlin Bronze



“Bronze” in the index evaluation,
“Silver” in the subjective evaluation.

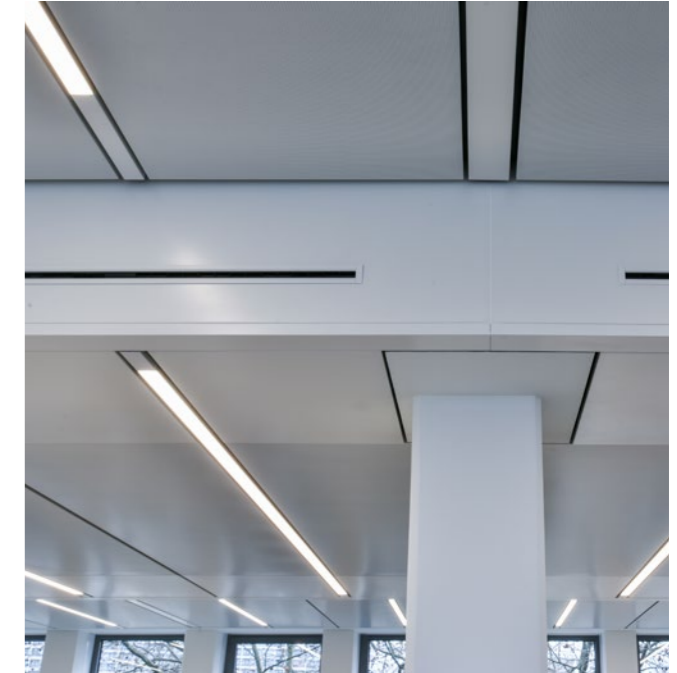

Re-Use – Quantity, Dimensions, Designation – The Most Frequently Delivered Materials

Quantity	Unit	Designation
216	pcs.	KLH 2491,3 x 910 mm T10 0,8 mm
185	pcs.	KLH 2491,3 x 910 mm T9 0,8 mm
180	pcs.	KLH 2320,8 x 910 mm T04 0,8 mm
159	pcs.	KLH 2320,8 x 910 mm T03 0,8 mm
127	pcs.	KLH 2491,3 x 910 mm T16 0,8 mm
125	pcs.	KLH 2491,3 x 910 mm T15 0,8 mm

Quantity	Unit	Designation
220	pcs.	KLH T10

Index Evaluation

Clip-in system: 10 points
 Powder coating: 15 points
 White color: 15 points
 Special lengths: 5 points
 Quantity >500: 15 points
 Age <10 years: 15 points
 Building type Office: 15 points
 Cooling ceiling: YES Factor 0.75
Total: 67.50 points

→ **Standard: Bronze**

Facts

- **Ceiling system:** Hang-in system – long-panel cassettes
- **Function:** Acoustics, cooling
- **Dimensions of the panels:** 2491.3 x 910 mm | 2320.8 x 910 mm
- **Perforation:** Rg 1.6 – 20%, smooth
- **Surface finish:** RAL 9016, traffic white
- **Area:** 4,370 m²

Subjective Evaluation

A good architect will be able to reuse or re-design more than 70% of the system. That is why, for me, it deserves a Silver rating rather than Bronze.

→ **Standard: Silver**

Andreas Fürthauer,
Auth. Signatory



With its modular ceiling elements and clearly defined grid dimensions, the system fulfills important criteria for re-use. The understated white design and easy accessibility make the ceiling installation at the Copenhagen International School a solid candidate for future reuse.

→ **Standard: Silver**

Tobias Todt,
Auth. Signatory Brünsh



The project in Berlin includes a good quantity of metal panels in a standard color. However, due to the very specific panel formats, their integration into a re-use project is somewhat more challenging. The neutral color scheme, however, has a positive effect on potential future reuse.

→ **Standard: Silver**

Gordon Kipping,
Technical Sales



Herzzentrum, Ludwigshafen Gold oder Bronze



“Gold” in the index evaluation,
“Bronze” in the subjective evaluation.

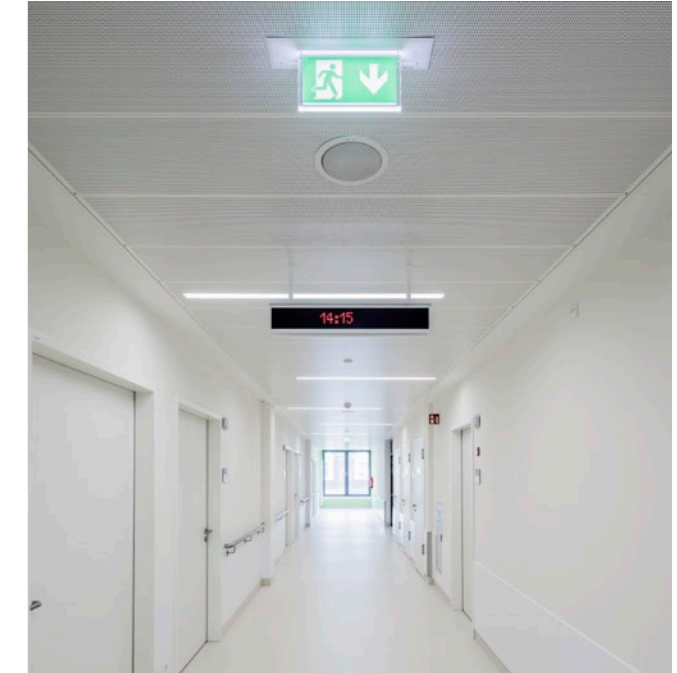

Re-Use – Quantity, Dimensions, Designation – The Most Frequently Delivered Materials

Quantity	Unit	Designation
1204	pcs.	KQK DOOR 625 × 625 mm 0.5 mm, smooth, color 9010
392	pcs.	SW 2000 × 397 mm 0.7 mm, black fleece inserts – assorted, 2516, color 9010
336	pcs.	KQK DOOR 625 × 625 mm 0.5 mm, 2516, color 9010
243	pcs.	CC 2000 × 397 mm 0.7 mm, black fleece inserts – assorted, 2516, color 9010
125	pcs.	SW 2000 × 397 mm g 0.7 mm, smooth, color 9010
123	pcs.	SW 1800 × 397 mm 0.7 mm, black fleece inserts – assorted, 2516, color 9010

Quantity	Unit	Designation
1204	pcs.	KQK-DOOR 625x625

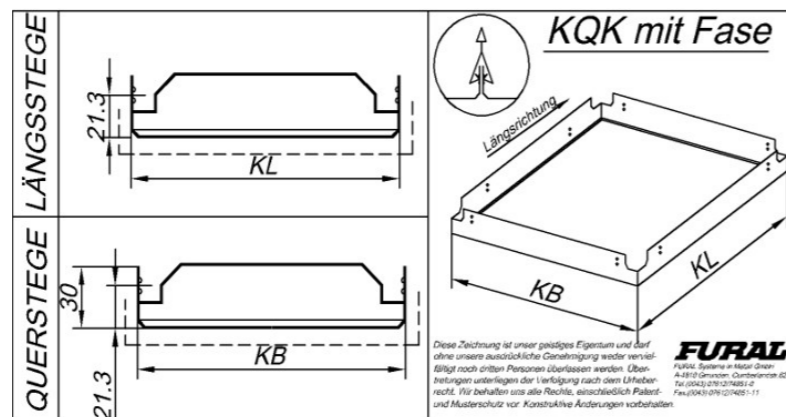

Index Evaluation

Clip-in system KQK: 15 points
Powder coating: 15 points
White color: 15 points
Standard length: 15 points
Quantity >500: 15 points
Age <10 years: 15 points
Building type Health: 10 points
Cooling ceiling: NO Factor 1.00
Total: 100.0 points

→ **Standard: Gold**

Facts

- **Ceiling system:** Clip-in system – square panels
- **Function:** Acoustics, accessibility for maintenance, fire protection, hygiene, lighting
- **Dimensions of the panels:** 625 × 625 mm | 2000 × 397 mm | 1800 × 397 mm
- **Perforation:** Rg 2.5 – 16%, smooth
- **Surface finish:** RAL 9010, pure white

Subjective Evaluation

The installed metal ceilings cover large areas, feature subtle colors, and follow common grid dimensions – making them fundamentally well suited for re-use. However, in a hospital environment, increased wear due to intensive cleaning procedures must be expected.

→ **Standard: Bronze**

Martin Richter, Innovation and Product Management



The ceilings are technically very well designed: large, uniform surfaces, standardized panels, and subtle colors. However, hygiene plays a crucial role in medical environments – which means frequent cleaning procedures. Re-use is certainly conceivable, but only with additional inspection and verification efforts.

→ **Standard: Bronze**

Christoph Kloibhofer, Technical Consulting



The large-area metal ceilings with neutral colors and standard formats generally provide very good conditions for re-use. However, due to the intensive use within a hospital environment and frequent cleaning procedures, careful inspection of the panels is required – re-use is possible, but with certain limitations.

→ **Standard: Bronze**

Christian Demmelhuber, CEO Fural Group



We Are Proud of Our Projects

Good Architecture:
Visit our references at www.fural.com

- The Edge Amsterdam** – Selected as the World's Most Sustainable Building According to BREEAM Certification
- International School Copenhagen** – A School Built to the Highest Standards
- Palais de Justice in Paris** – From Gmunden to Paris, We Are Proud
- Scott Headquarters in Switzerland** – Perfect Form, Function, and Color
- Vienna Airport** – Skylink with Fural Metal Ceilings
- Waldklinikum Eisenberg** – Matteo Thun Designs and Builds Sustainably with Fural Metal Ceilings

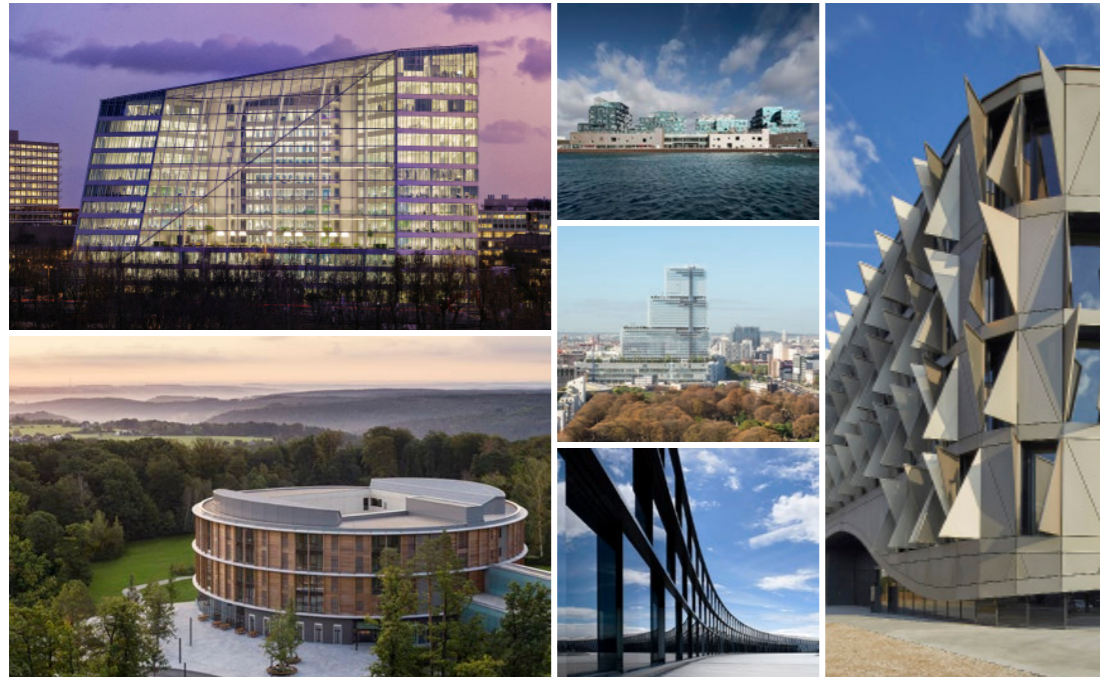

Expanded Metal – Product of the Year 2022, 2023, 2025

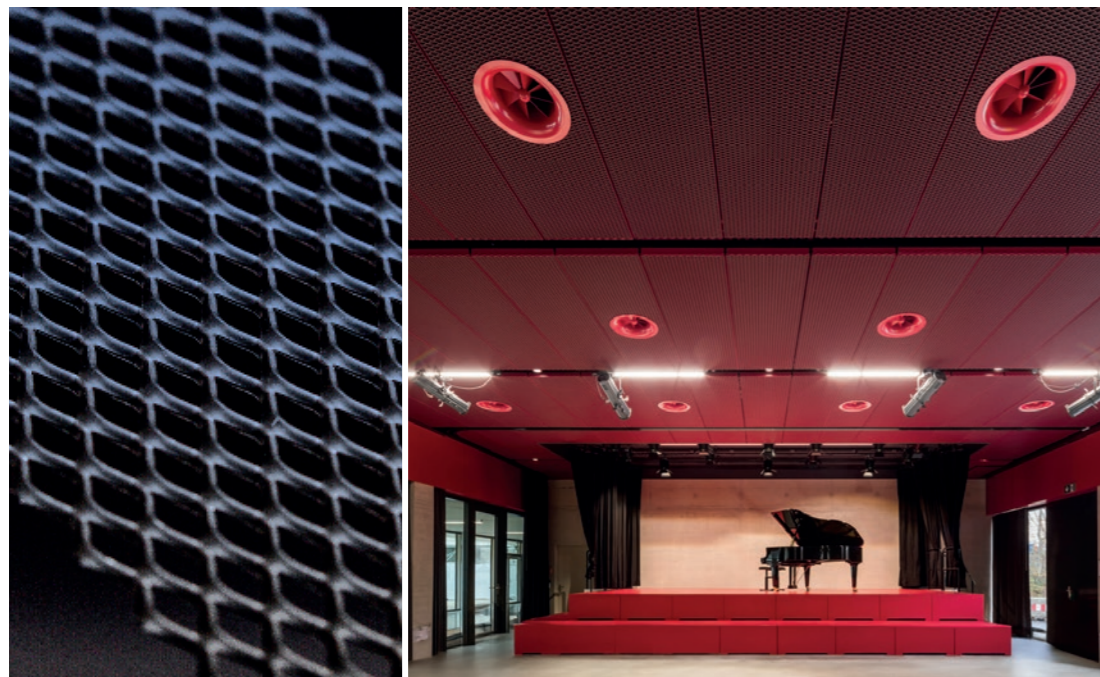

We Are Proud of Our Projects

Innovation: Acoustic Guide Profile with
-20% Energy Consumption, +20% Acoustics

DAGA 2026 – 52nd Annual Conference on Acoustics, March 23–26, 2026 in Dresden
The following image shows a wall covering from the DAGA trade fair stand.
Many leading acoustic engineering firms design with Fural products.

INNOVATION ALP – Akustikleitprofil

Optimierte Akustik & Effizienz für Heiz-/Kühldecken
+ 20 % Akustik / Schallabsorption
+ 20 % Heiz- & Kühlleistung

- Effizientere Wärmeübertragung
- Bessere Verteilung des Kältesees auf der Decke

Materialeffizient & nachhaltig

- 28 % Materialeinsparung bei gleicher Leistung (0,35 statt 0,5 mm Wandstärke)
- sortenreine Trennung der Materialien Stahl, Alu und Kupfer möglich - Wertstoffe der Zukunft

Akustische Leistungsdaten geschlossene Decke

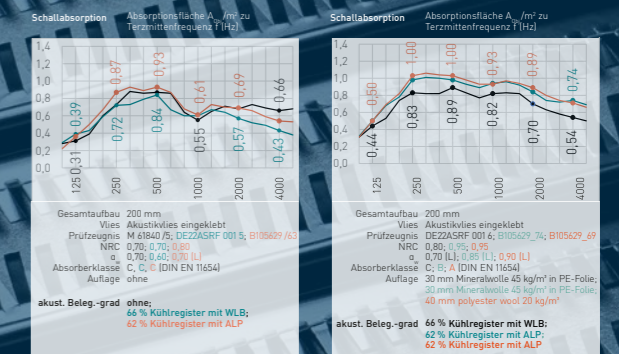

Akustische Leistungsdaten Segel

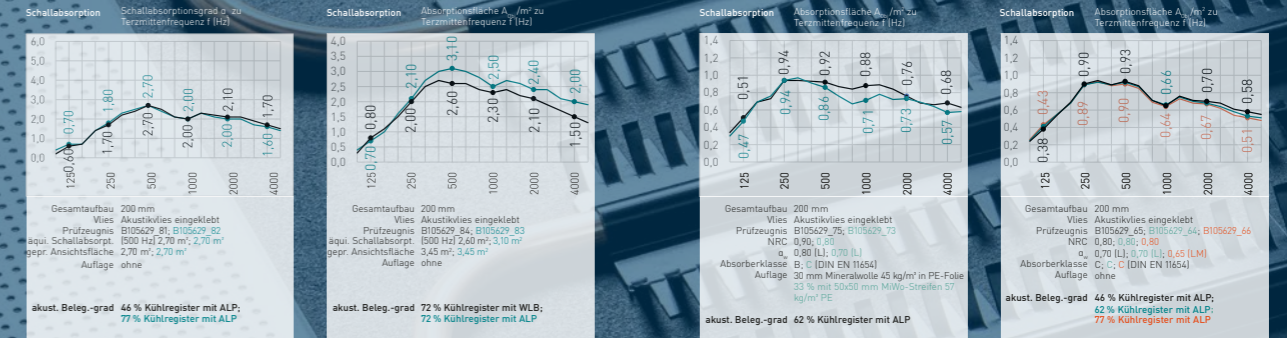

We Are Proud of Our Projects

Winner of the Innovation Award at the World's Leading Trade Fair BAU Munich

This Is What Winners Look Like:

Dirk Freytag and Martin Richter with the Innovation Award at BAU Munich for replaceable LED luminaires.

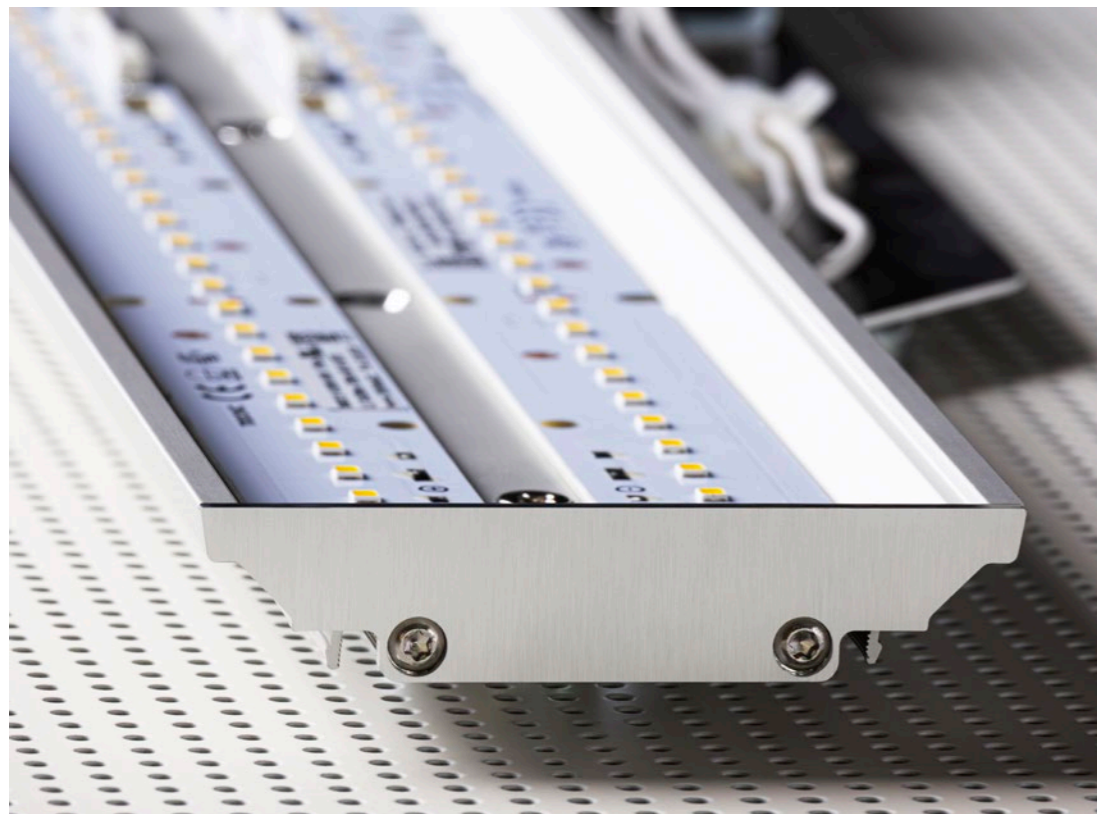

We Are Proud of Our Projects

New – Soft Acoustics at Fural

Fural Takes Over Machines and Employees from pinta systems GmbH in Maisach

Fural Systeme in Metall GmbH has acquired the machines and test reports for the acoustics division from the insolvent pinta systems GmbH and has also integrated many former employees into its team. All products – including Float Polar, Balance Polar, Balance, Balance Plus, Balance Art, Plano Polar, Plano, Plano A2, Absorber Plano Polar, Absorber Plano, Absorber Rondo, Pyramide, and Waffel Polar – are now marketed under the name “Soft Acoustics.”

General:

The acoustic elements from Soft Acoustics are based on the two innovative core materials PET and Basotect. The materials are free from mineral fibers and adhesives. They are recyclable and support a closed material cycle. They offer high sound absorption, extremely low weight, and flexible design possibilities. The lightweight construction is further enhanced through lighting design. The elements feature a high degree of prefabrication, enabling fast installation.

PET:

Fural POLAR is a 100% pure PET sandwich element manufactured without the use of binding agents or adhesives. As a result, the material can be easily separated by type at the end of its service life and returned to the raw material cycle. The material is formaldehyde-free, produced without chemical additives, and already consists of up to 70% recycled fibers, for example from PET bottles. The material meets the criteria for a healthy indoor environment and has been awarded Class 1 certification according to the Oeko-Tex Standard 100. Fural POLAR is allergy-friendly, low-odor, and toxicologically completely harmless. The material is also breathable, vapor-permeable, and free from fiber dust. The sandwich elements are UV-resistant and flame-retardant (according to DIN EN 13501: for material thicknesses up to 20 mm: B-s1 d0, for 20–40 mm: B-s2 d0). The surfaces can be coated and printed.

Melamine Resin Foam:

Basotect is an open-cell melamine resin foam consisting of 99% air. Due to its material structure, Basotect offers excellent sound absorption while remaining extremely lightweight. The material is soft and flexible, yet dimensionally stable and highly durable. Basotect can be freely shaped, is available in various colors, and can be printed with custom motifs. It complies with fire protection class B1, flame-retardant (according to DIN EN 13501: for material thicknesses up to 5 mm: B-s1 d0, for 20–30 mm: C-s1 d0, for 40–80 mm: C-s2 d0) prototypes.



Floating Ceiling Systems

Float Polar

- Highly effective acoustic floating ceiling
- Acoustic element made of laminated PET sandwich panels, frameless
- Flexible sizes up to 2,500 × 1,250 mm
- Round versions up to Ø 1200 mm
- Free-form shapes possible
- Areas of application: offices and conference rooms, canteens, event spaces, educational facilities, kindergartens



Soft Acoustics | Round Floating Ceilings in the Canteen

Geprüfte Perforationen

Beispiele für gängige, geprüfte Perforationen für geschlossene Decken

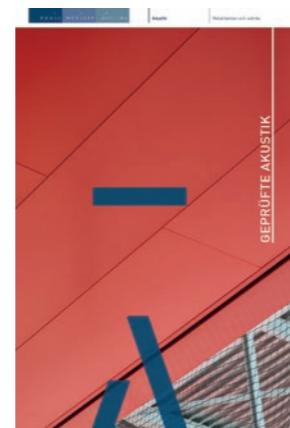
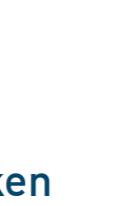

1. Download geprüfte Akustik Broschüre
2. Download alle 300 geprüften Akustikaufbauten der Metall Akustik

Verschiedene Perforationen

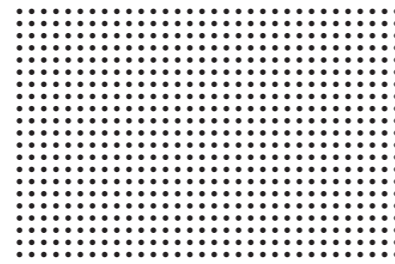
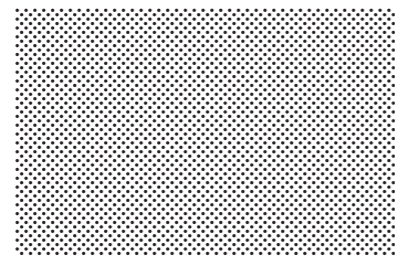
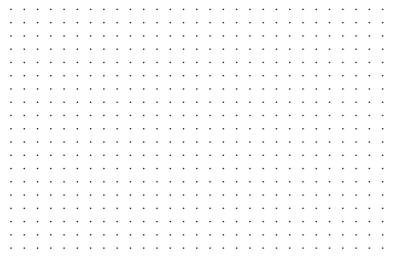

Rg 0,7-1%

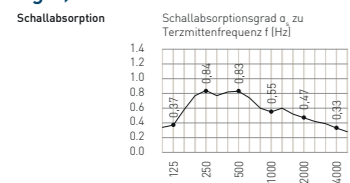

Gesamtaufbau 200 mm
Vlies Akustikvlies eingeklebt
Prüfzeugnis P-BA 231/2007
NRC 0,65
alpha_s 0,50 [LM], 0,80
Absorberklasse D [DIN EN 11654]
Auflage ohne

Rd 1,5-22%

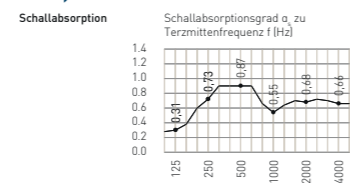

Gesamtaufbau 200 mm
Vlies Akustikvlies eingeklebt
Prüfzeugnis 07/12/2010 M61840/5
NRC 0,70
alpha_s 0,70
Absorberklasse C [DIN EN 11654]
Auflage ohne

Rg 2,5-16%

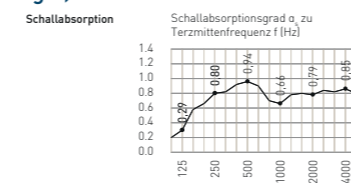

Gesamtaufbau 200 mm
Vlies Akustikvlies eingeklebt
Prüfzeugnis P-BA 279/2006 Bild 1
NRC 0,80
alpha_s 0,80
Absorberklasse B [DIN EN 11654]
Auflage ohne

Einfluss des Lufthohlräumens

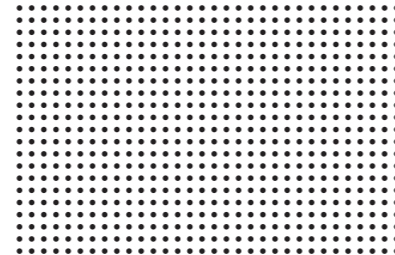
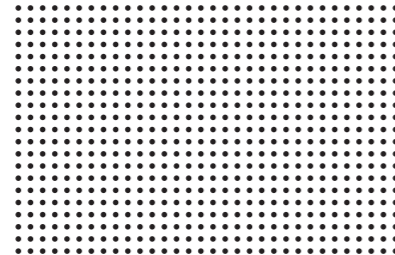
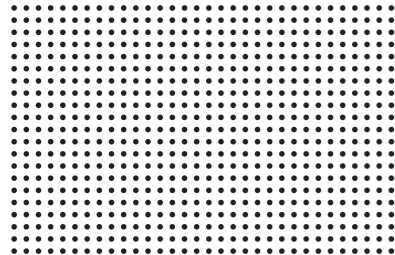

Rg 2,5-16%

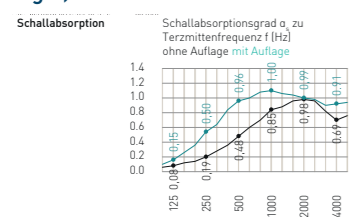

Gesamtaufbau 50 mm
Vlies Akustikvlies eingeklebt
Prüfzeugnis P-BA 279/2006 Bild 20
NRC 0,65; 0,90
alpha_s 0,50 [MH], 0,80
Absorberklasse D [DIN EN 11654], B [DIN EN 11654]
Auflage 30 mm Mineralwolle 45 kg/m³

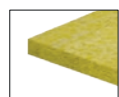

Rg 2,5-16%

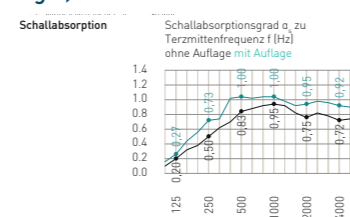

Gesamtaufbau 100 mm
Vlies Akustikvlies eingeklebt
Prüfzeugnis P-BA 279/2006 Bild 21
NRC 0,75; 0,95
alpha_s 0,80; 0,95
Absorberklasse B [DIN EN 11654], A [DIN EN 11654]
Auflage 30 mm Mineralwolle 45 kg/m³

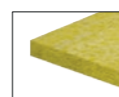

Rg 2,5-16%

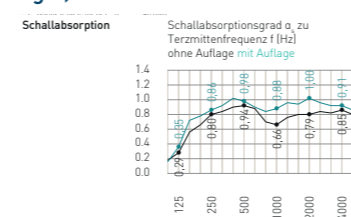

Gesamtaufbau 200 mm
Vlies Akustikvlies eingeklebt
Prüfzeugnis P-BA 279/2006 Bild 1
NRC 0,80; 0,95
alpha_s 0,80; 0,95
Absorberklasse B [DIN EN 11654], A [DIN EN 11654]
Auflage 30 mm Mineralwolle 45 kg/m³

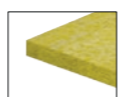

Nachhaltige Metalldecken von Fural



- Einhaltung der gesetzlichen CO₂e/m²-Vorgaben mit Metalldecken von Fural
- CO₂e in allen Angeboten transparent ausgewiesen
- Bis zu -76 % CO₂e im Vergleich zu normalem Stahl dank greentec steel Edition 600 von voestalpine
- CO₂e/m² für normalen Stahl, greentec steel Edition und greentec steel Edition 600

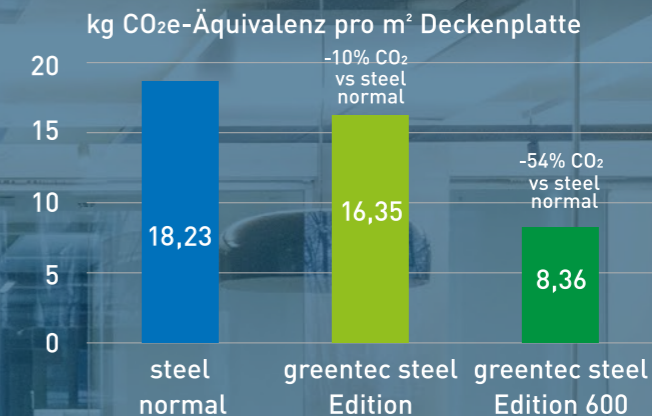

Metalldecken – doppelt nachhaltig

Produktion

- 100 % recycelbares Material.
- Recycling: Im Vergleich zur Primärproduktion werden ca. 75 % CO₂e eingespart.

Nutzung

- Lebensdauerklasse von mehr als 50 Jahren.
- Metalldecken sind robust, Re-Use-fähig und Metall ist kein Sondermüll und hat seit Jahrzehnten ein bewährtes Recyclingsystem. Metall ist Wertstoff der Zukunft.

Fural Nachhaltigkeitspodcast



- Nachhaltigkeit bei Fural
- Warum ist Nachhaltigkeit wichtig?
- Zertifizierungen
- CO₂
- Stahl – Das Rohmaterial der Metaldecke
- Kreislaufwirtschaft Teil 1
- Kreislaufwirtschaft Teil 2 Madaster
- Zukunft des Bauens, Dr. Weidner von W. Sobek AG

We Are Proud of Our Projects

Automatically Sent by Email with Delivery Documents or Available Upon Request
Material / Building Resource Passport for Re-Use

By focusing on durable, high-quality products, less waste is generated. Resources such as metals, plastics, and electronic components remain within the cycle and do not need to be constantly extracted and newly produced.

Bills of materials help support the planning of re-use.

Starting with the Table of Contents for an Overall Overview

Inhaltsverzeichnis

EINGABEWERTE für Gebäderessourcenpass ähnlich DGNB	Seite	1-3
Material-/Ressourcenpass in der Theorie	Seite	4
Re-Use – Menge, Abmessung, Bezeichnung – die am häufigst gelieferten Materialien	Seite	5
Re-Use – die häufigst gelieferten Materialien mit Positionstext und Zeichnung	Seite	6-8
Re-Cycle – Überblick über Gesamtmengen	Seite	9

Input Values for a Building Resource Passport Similar to DGNB

Inhalte für Gebäderessourcenpass	Daten / Eingabe	[Einheit] / Verfahren / Detailwert / Definition	Datenqualität / (Erläuterung)	Index (DQI)	Relevanz / Vollständigkeit	Betrachtungsebene
NR [Fett]	ABSCHNITT auf Ausgabe-Blatt '1-GRP-vol/red' (3-stellige Nr.: 1.Ziffer = Abschnitts-, 2.Ziffer = Thema-Nr., 3.Ziffer= lfd.)	Auswahlfeld [Drop-Down-Liste] 'Eigene Beschreibung' auf Blatt 'Drop-Down'	Klassifikation 1 z.B. Methode zur Datenermittlung N/A / nicht verlässlich geschätzt / ungenau gemessen / berechnet Datenbank / Modell	0 1 2 3	Pflichtinformation (mind. Angabe N/A)	Gebäude
NR [Normal]	auf Zusatzblättern 2-7 (OPTIONAL) (Systematik für Nr.-Ergänzungen: Ziffern [1, 2, 3, etc.] = der Nr. als Detailinformation / -kennwert zugeordnet; Buchstaben [a, b, c, etc.] = Eingabewerte auf Bauteil-/Schicht-/Produktenebene)	Eingabefeld (zur freien Eingabe)	Klassifikation 2 z.B. Prozentanteil der Datenermittlung nicht vorhanden / nicht verlässlich 0-90 90-95 95-100	0 1 2 3	Kann-Information (optional)	Bauteil / Schicht (über Filter ausgeblendet! Keine Eingabe! (Formatvorlage für Eingabewerte, die auf Bauteil- / Schicht- / Produktebene zu ermitteln sind!)
0	Projekt-Informationen					
1	Gebäudeinformationen und Gebäudemassen			0,00		
108a	Kostengruppe und / oder Gewerk und / oder Zuordnung zu "Funktionalen Bauteilen"	350	Datenbank / Modell	-	Kann-Information	Bauteil
109a	Referenz-Nutzungsdauer des Bauteils / der Bauteilschichten / des Produkts	>=50 [a]	-	-	Kann-Information	Bauteil / Schicht
110a	Gesamtmasse des Bauteils / Produkts / Materials bzw. der Bauteilschicht	28 063,13 [kg]	gemessen / berechnet	-	Kann-Information	Bauteil / Schicht
120a	Bauteil oder Bauteilschicht	350 Decken, horizontale Baukonstruktionen	-	-	Kann-Information	Bauteil / Schicht
	Deckenfläche im Abruf	4 053,29 m ²	-	-	Kann-Information	Bauteil
	Gesamt CO ₂ e-Emissionen des Produktionsabrufs CO ₂ e-Emissionen/m ²	78 296,14 kaCO ₂ e	-	-	Kann-Information	Bauteil
	CO ₂ e-Emissionseinsparungen pro m ² durch greentec steel Edition 600 ggü. durchschnittlichem Stahl [worldsteel-LCA]	19,32 kaCO ₂ e/m ²	-	-	Kann-Information	Bauteil
	CO ₂ e-Emissionen/m ² bei Verwendung von greentec steel Edition 600	-13,09 kgCO ₂ e/m ²	-	-	Kann-Information	Bauteil
	CO ₂ e-Emissionen/m ² bei Verwendung von greentec steel Edition 600 ggü. durchschnittlichem Stahl [worldsteel-LCA]	6,23 kgCO ₂ e/m ²	-	-	Kann-Information	Bauteil
	Prozentuelle CO ₂ e-Emissionen/m ² -Einsparung bei Verwendung von greentec steel Edition 600 ggü. durchschnittlichem Stahl [worldsteel-LCA]	68 %	-	-	Kann-Information	Bauteil
2	Materialität, Materialherkunft, Schad- und Risikostoffe sowie Bau- und Abbruchabfälle			0,56		
201	Materialität des Bauwerks	Verweis Datenquelle: EPD, 100 [Masse-%]	gemessen / berechnet	2	Pflichtinformation	Gebäude
201.4	Materialität: Materialmix	3,00 [Masse-%]	-	-	Pflichtinformation	Gebäude / Bauteil
201.6	Materialität: Metalle	97,00 [Masse-%]	-	-	Pflichtinformation	Gebäude / Bauteil
201a	Materialität des Bauteils / Produkts bzw. der Bauteilschicht	100 [Masse-%]	Daten extern geprüft	-	Kann-Information	Bauteil / Schicht

We Are Proud of Our Projects

Podcast – 8 Episodes from Circular Economy to Madaster



Teaser – What Does Climate Neutrality Mean at Fural?

Speaker Thomas Gruber, together with interview guests, explains the key climate-responsible topics that will become unavoidable for companies like Fural in the future. The co-founder of TWENTY-40 comes from the construction industry and brings extensive experience in the field of sustainability.

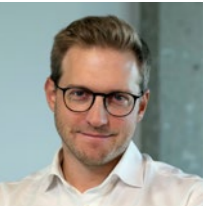

Thomas Gruber

Episode 1 – Sustainability at Fural

What does climate neutrality mean at Fural? How do the Green Deal, the EU Taxonomy, and the CSRD (Corporate Sustainability Reporting Directive) affect our work? In our podcast, we explore these exciting questions surrounding sustainability.



Dirk Freytag

Episode 2 – Why Is Sustainability Important?

Why are we focusing on sustainability? Because we have a responsibility! What happens if we change nothing and continue living as before?



Martin Richter

Episode 3 – Certifications

What contribution can Fural and metal ceilings make toward building certification? How many buildings are being certified, and which certification systems exist?

Episode 4 – CO₂

How is Fural addressing the topic of CO₂? What does Fural offer its customers regarding CO₂, and how does Fural calculate its own carbon footprint?



Andreas Fürthauer

Episode 5 – Steel – The Raw Material of Metal Ceilings

How are steel and green steel produced, and why is this transformation not possible overnight?

Episode 6 – Circular Economy Part 1

The circular economy is a central element of sustainability. If components can no longer be repaired or reused, they should be recovered and recycled. What does circular economy mean for metal and for Fural?

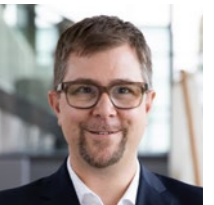

Mag. Werner Weingraber

Episode 7 – Circular Economy Part 2: Madaster

The circular economy is a central element of sustainability. If components can no longer be repaired or reused, they should be recovered, recycled, and kept out of landfills as much as possible. What is a metal resource passport, and what does it have to do with sustainability?

Episode 8 – The Future of Construction, Dr. Weidner from W. Sobek AG

Dr. Stefanie Weidner, Managing Director and Board Member of Werner Sobek AG, discusses the future of construction and the role of steel, green steel, and CO₂.



Dr. Stefanie Weidner

We Are Proud of Our Projects

Klimaaktiv – Fural Office Achieves Silver Standard

Die Klimaaktiv Gebäudezertifizierung ist das meistverbreitete Bewertungssystem in Österreich für Gebäude. Da Nachhaltigkeit auch in der Baubranche immer wesentlicher wird, hilft Klimaaktiv nachhaltig zu bauen. Dabei werden alle 3 Säulen der Nachhaltigkeit bewertet: ökologische, ökonomische und soziale.

Die Gebäudezertifizierung ist in vier Bereiche aufgeteilt um die 1000 möglichen Punkte zu erreichen:

- A Standort: 150 Punkte
- B Energie und Versorgung: 550 Punkte
- C Baustoffe und Konstruktion: 150 Punkte
- D Komfort und Gesundheit: 150 Punkte



Es sind drei verschiedene Qualitätsstufen der Zertifizierung möglich:

- Bronze alle MUSS-Kriterien
- Silber 750 Punkte + MUSS-Kriterien
- Gold 900 Punkte + MUSS-Kriterien

A (Standort): 122/150

Grün- und Freiflächenindikator: Trotz perfekter Außenplanung nur 11/50 Punkten. Hier lassen die Rahmenbedingungen nicht mehr zu.

B (Energie und Versorgung): 502/550

Thermische Flexibilität des Gebäudes: 0/50 Punkten - mit Gebäudesimulation noch bis zu 48 Punkte möglich
PV-Erträge: 0/80 Punkten - Statisch nicht möglich.

C (Baustoffe und Konstruktion): 90/150

PVC – Freiheit: 10/50 Punkte – PVC freie Abdichtungen, Halogenfreie Elektroinstallation und PVC freie Fenster nicht umgesetzt.
Kältemittel: 0/20 Punkte - Bei Bestellung der Kältemaschine war diese Anforderung noch nicht bekannt.
Entsorgungsindikator: 0/40 Punkte – Wurde nicht erstellt. Abklärung über Machbarkeit und Kosten laufen gerade.
Rückbaukonzept: 0/20 Punkten – Nicht mehr möglich, da keine Schadstofferkundung vor der Sanierung gemacht wurde.

Bereich D (Komfort und Gesundheit): 101/150

Thermischer Komfort im Sommer: 22/50 Punkte – Durch hohe Kühllast des Gebäudes sind hier nicht mehr Punkte möglich.
Produktmanagement: 0/80 Punkten – Mit diesem Punkt hätte schon in der Ausschreibungsphase begonnen werden müssen.

Ein Punktepuffer ist notwendig, da uns in der Bewertungsphase noch Punkte gestrichen werden können.



Silber		
815		
von 1000 möglichen Punkten		
Standort		
A	150	122
Energie und Versorgung		
B	550	502
Baustoffe und Konstruktion		
C	150	90
Komfort und Gesundheit		
D	150	101

We Are Proud of Our Projects

Products of the Year Baffle and Expanded Metal

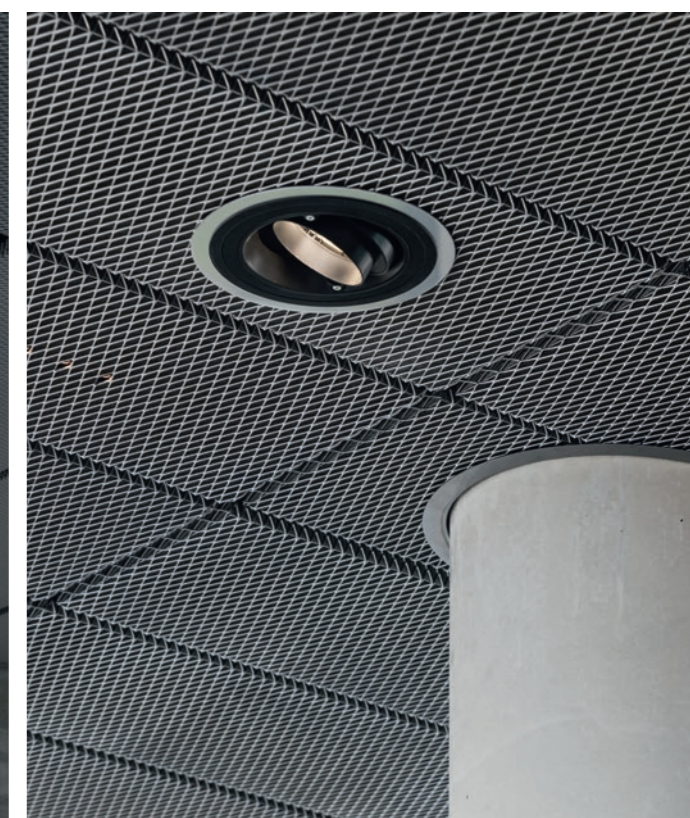
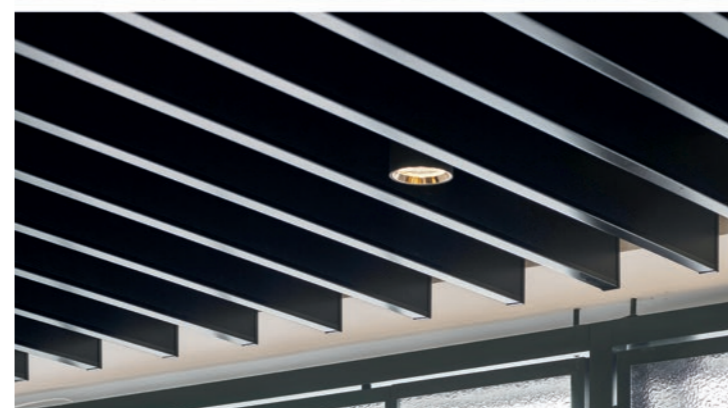

Inside Fural

10 Examples of Optimizing Energy and Emissions in Construction and Operation

Example 1: Reducing Gas or Heating Oil Consumption per m²

CO₂ from gas or heating oil per m² from 2019 to 2024:
 → Fural: from 1.70 to 1.23 kg CO₂/m²
 → Metalit: from 3.18 to 2.36 kg CO₂/m²
 → Dipling: from 1.45 to 0.98 kg CO₂/m²

Gmunden, AT

YEAR	GAS CONSUMPTION				ELECTRICITY CONSUMPTION			
	kWh/Year	m ³ /Year	kWh/m ²	kg CO ₂ /Year	kWh/Jahr	m ² /Year	kWh/m ²	kg CO ₂ /Year
2020	3 485 482	633 365	5,50	1 042 159	1 608 683	633 365	2,54	316 911
2021	3 932 782	723 106	5,44	1 175 902	1 571 732	723 106	2,17	350 496
2022	3 630 949	678 863	5,35	1 085 654	1 761 716	678 863	2,60	431 619
2023	3 013 600	721 845	4,17	901 066	1 773 496	721 845	2,46	299 721
2024	2 566 966	623 450	4,12	768 126	1 809 914	623 450	2,90	224 341

-14,75%

Example 2: Reducing Electricity Consumption per m²

CO₂ from electricity per m² from 2019 to 2024:
 → Fural: from 0.60 to 0.36 kg CO₂/m²
 → Metalit: from 0.61 to 0.14 kg CO₂/m²
 → Dipling: from 1.02 to 0.75 kg CO₂/m²

Büren, CH

YEAR	HEATING OIL CONSUMPTION				ELECTRICITY CONSUMPTION			
	kWh/Year	m ³ /Year	kWh/m ²	kg CO ₂ /Year	kWh/Year	m ² /Year	kWh/m ²	kg CO ₂ /Year
2020	177 904	218 730	0,81	608 447	895 297	218 730	4,09	91 320
2021	211 131	271 100	0,78	722 110	1 064 599	271 100	3,93	129 881
2022	182 651	272 526	0,67	624 703	879 740	272 526	3,23	121 917
2023	152 102	288 651	0,53	520 219	841 243	288 651	2,91	71 506
2024	150 848	218 393	0,69	515 930	712 158	218 393	3,26	29 843

-00,01%

The next step (2025) would be the practical implementation of CRREM pathways for the company's own properties and production facilities.

Hungen, DE

YEAR	HEATING OIL CONSUMPTION				ELECTRICITY CONSUMPTION			
	kWh/Year	m ³ /Year	kWh/m ²	kg CO ₂ /Year	kWh/Year	m ² /Year	kWh/m ²	kg CO ₂ /Year
2020	60 991	188 090	0,32	208 601	371 173	188 090	1,97	144 015
2021	53 236	178 382	0,30	182 078	368 679	178 382	2,07	161 850
2022	46 837	180 021	0,26	160 192	372 277	180 021	2,07	176 832
2023	75 583	160 526	0,47	258 509	363 031	160 526	2,26	145 212
2024	46 036	160 109	0,29	157 452	357 851	160 109	2,24	119 522

-39,09%

CONSOLIDATED

YEAR	ENERGY CONSUMPTION				ELECTRICITY CONSUMPTION			
	kWh/Year	m ³ /Year	kWh/m ²	kg CO ₂ /Year	kWh/Year	m ² /Year	kWh/m ²	kg CO ₂ /Year
2020	5 826 453	1 040 185	5,60	1 859 228	2 875 153	1 040 185	2,76	552 246
2021	6 523 579	1 172 588	5,56	2 080 090	3 005 010	1 172 588	2,56	642 227
2022	6 102 337	1 180 737	5,17	1 937 048	3 122 071	1 180 737	2,64	798 127
2023	5 427 176	1 221 984	4,44	1 734 291	3 083 656	1 221 984	2,52	569 382
2024	4 680 774	1 044 616	4,48	1 496 024	2 989 837	1 044 616	2,86	419 351

-13,74%

Example 3: Strengthening Maintenance Through Optimized Storage Areas and Expanding the Team from Two to Three People

Fewer machine failures mean improved energy efficiency, quality improvement and CO₂ reduction require smart thinking and the best people.

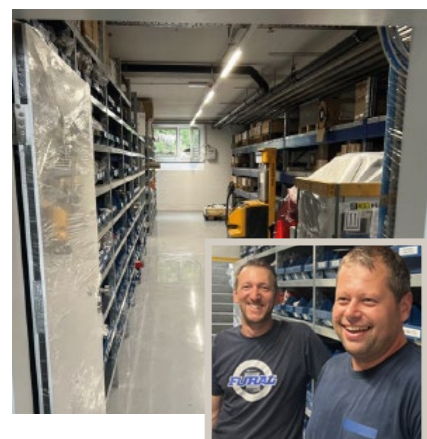

Example 4: Paint System Conversion at the Hungen Site

Improved quality through greater coating thickness; More support and service; Reduced waste

→ Complaint rates reduced by more than 60%



Example 5: Maximum Building Optimization – Klimaaktiv Silver Standard for the New Gmunden Office; From the Alpenjäger Barracks to the Elefanten Shoe Factory; From the Elefanten Shoe Factory to the Fural F1 Office in Gmunden

Silber		
815 von 1000 möglichen Punkten		
Standort		
A	150	122
Energie und Versorgung		
B	550	502
Baustoffe und Konstruktion		
C	150	90
Komfort und Gesundheit		
D	150	101

Inside Fural

10 Examples of Optimizing Energy and Emissions in Construction and Operation

Example 6: Energy-Efficient Renovation of the Building Envelope

From 330 kW/m² to 25 kW/m²



Bewertung Nicht-Wohngebäude: Heizwärmebedarf HWB_{ref,BK} gemäß OIB Richtlinie 6 - 2019*
 Es müssen alle drei Felder ausgefüllt werden.

HWB _{ref,BK} in kWh / m ² a gemäß OIB RL6-2019	31,83 kWh / m ² _{BGR-a}
Bruttoraumhöhe BRH	4,27 m
lc = V / A gemäß OIB RL6	1,7 m
Vergleichswert vor der Sanierung	
HWB _{ref,BK} in kWh / m ² _{BGR-a} gemäß OIB RL6 - 2019	279,86 kWh / m ² _{BGR-a}

-88,6%

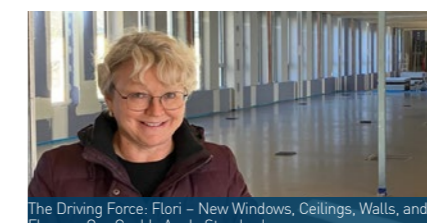

Example 7: From Oil Heating to District Heating for the Gmunden Office



Example 8: Inbetriebnahme 10.2024 von PV-Büren = 353 kW-Peak



Example 9: Use of greentec steel Edition 600 for Office Ceilings = 66% Less CO₂ Compared to Conventional Steel

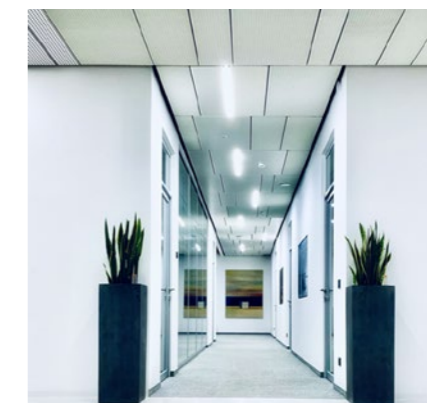

Example 10: Infrastructure for Private and Business Charging of Electric Vehicles in Büren

In Büren, employees can charge their vehicles at the company for a flat rate of CHF 30 per month. Shown in the picture are our employees Schube and Alex.

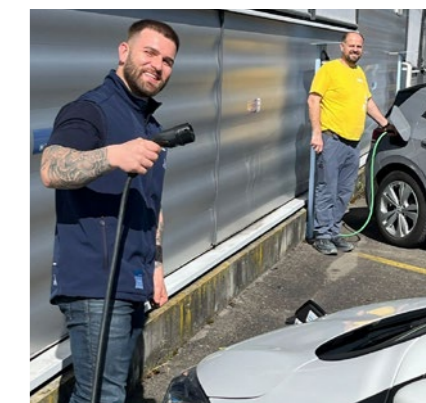

Inside Fural

7 Examples of Satisfied Employees,
Supporting Both Regionally and Internationally

Example 1: Employees – Ten Voluntary Benefits Developed for 2024 / 2025

Zehn freiwillige Benefits für Mitarbeiter in 2024/2025 für Gmunden

- ✓ 1. Nachwuchs fördern
 - ✓ a. Tobias Franke „Wien“ ermöglichen
 - ✓ b. Zedan Serdar von Anlagenführer PB zum Programmierer, beginnend im Einkauf
 - ✓ c. Tanja Pavic, Alex Skoric, Salih Halili, Gülen Onür zum möglichen Anlagenführer ausbilden.
 - ✓ d. Riccardo Puglisi, Sandi Ramakic in die Kalkulation
 - ✓ e. Neueinsteiger aus Umfeld Firma bewusst Chancen geben, z.B. Paul, Anna, Abi, Minela, Reka
 - ✓ f. Nachwuchskräfte bewusst mitnehmen: Akustik- oder BS-Prüfungen, Messen, Lieferantenbesuche...
- ✓ 2. Drei Monate jährlich freies Eis – immer im Juni, Juli, August und September
 - Investition in Kühlschränke für jeden Standort/Betriebsstätte
 - Und viel, viel, viel Eis.
- ✓ 3. Vorhandene Standards weiterhin wertschätzen
 - Wertschätzung von Ehrenamt, zusätzlich 1 Tag Urlaub
 - Müsli, Yoghurt, freies Wasser
 - Vital Box – gesunde Box für Mitarbeiter
 - Eintrittskarten für Basketball und Fußball in Gmunden
 - Fural-Boot
 - Business-Bike
 - Goldmünze bei Geburt
 - 4x Eintrittskarten Red Bull Salzburg
 - Jahresbeginn mit neuer Arbeitskleidung
- ✓ 4. Investition 1: Büroarbeitsplätze auf Top-Standard
 - a. Höhenverstellbaren Tische als Standard
 - b. Beste Klimatisierung
 - c. 2x Heiss- und Kaltwasserspender
- ✓ 5. Investition 2: Neues Betriebsrestaurant perfekt für Mitarbeiter
 - a. Für private Feiern nutzbar
 - b. Eigener WC-Bereich, Spielbereich
 - c. Infrastruktur z.B. Spülmaschine, Kühlschränke passend für Firma und MA-Feiern
- ✓ 6. Pizzaofen auf Anhänger – gut nutzbar für Mitarbeiter
- ✓ 7. EIOS – psychologische Hilfe bei Ängsten
Gezielte Behandlung von Emotionen bei Angst- und Panikstörungen, Belastungsstörungen, Zwangserkrankungen, Essstörungen und psychosomatischen Krankheitszeichen.
www.eiostherapie.de
- ✓ 8. Eintrittskarten Basketball Swans von 3 auf 6 Karten
Drei Karten bei Bernhard Zierlinger / Büro.
drei Karten bei Fahri Kuleta / Produktion.
- 9. Amazon-Pakete an Fural – Hin-/Rücklieferung durch FURAL
- ✓ 10. Kulturhauptstadt Gmunden / Salzkammergut erleben
 - a. Gmunden / Führung durch Eva Fürthbauer, ca. 25 Personen
 - b. Traunkirchen Stollen Karbach und Russenvill
 - c. Ebensee: KZ-Gedenkstollen mit japanischer Künstlerin Chiharu Shiota.

Legend: A check mark indicates implemented measures.

Inside Fural

7 Examples of Satisfied Employees,
Supporting Both Regionally and Internationally

Example 2: Donation of Raffle Proceeds to Support Meaningful Regional Projects

At the 2024 Christmas raffle, a total amount of €341 was raised. The original amount was quadrupled, and additional generous donations were made by individual employees. As a result, a total of €1,364.00 was donated to charitable causes.



Example 5: The Fural Pizza Oven.

One professional pizza oven on a trailer available for all employees to borrow. Saving resources together – and frequently used.



Example 3: Two Additional Wells Donated in Cambodia.

In the village of Sreung, the 32 m deep well supplies 203 families, while in Peykes, the 30 m deep well supplies 358 families.

Fural donates one well for Cambodia every year. Wells 143, 202, 246, 307, and 403 were funded by Fural.



Example 6: The Alpine Hut – the Employee Gift for 30 Years of Metalit, Built on the Metalit Premises.

Frequently used for both company and private events.



Example 4: Company Porsche Appreciated in Hungen.



Example 7: 10 Employee Benefits – Three Months of Ice Cream Enjoyed at Every Location.



Jahrbuch 2024, Seite 58

Re-Use in Theory

Book “Material Matters, Chapter 5”

Thomas Rau and Sabine Oberhuber present concrete examples of how circular economy principles can be implemented:

The concept of “Light as a Service,” discussed in Chapter 5 of *Material Matters*, is an example of a paradigm shift from a linear to a circular economic model. Developed in collaboration with Philips, its goal is to make lighting more sustainable and resource-efficient.



Background of the Model

Traditionally, lighting manufacturers sell their products to customers, who are then responsible for maintenance, repairs, and ultimately disposal. This often results in lighting fixtures being replaced relatively quickly by newer models, creating large amounts of electronic waste and wasting valuable resources.

In contrast, the “Light as a Service” model focuses on providing a service rather than selling a physical product. This means:

Philips remains the owner of the lighting systems and leases the lighting performance to the customer.

The customer only pays for the use of light, similar to paying for electricity or water.

Philips is responsible for maintenance, repairs, and optimization of the lighting systems.

At the end of their service life, the lighting fixtures are taken back, re-used, or recycled instead of ending up in landfills.

How Does It Work in Practice?

This concept was implemented, among other places, at the headquarters of Schiphol Airport in the Netherlands:

1. Schiphol pays only for the light, not for the lamps.

Instead of purchasing lighting fixtures, the airport purchases light as a service. The lighting is provided according to demand, without Schiphol having to manage the hardware itself.

2. Philips guarantees maximum efficiency and durability.

Since Philips retains ownership of the lighting systems, the company has a direct economic interest in using durable and energy-efficient solutions, because every maintenance intervention and replacement creates additional costs.

3. Return and recycling at the end of the product life cycle.

Once the systems reach the end of their useful life, the materials are not discarded. Instead, Philips either reuses them in new lighting systems or recycles them.

Why Is This Model So Revolutionary?

Sustainability

By focusing on durable, high-quality products, less waste is generated. Resources such as metals, plastics, and electronic components remain within the cycle instead of constantly being newly extracted and manufactured.

Cost Savings for the Customer

Companies do not need to make large investments in new lighting systems. Maintenance and optimization are handled by Philips.

Incentive for Better Product Quality

Since Philips itself remains responsible for maintenance and replacement, it is in the company’s interest to manufacture durable and energy-efficient products rather than relying on planned obsolescence.

Promotion of the Circular Economy

This model demonstrates that the focus should not be on ownership of a product, but on its use. It encourages companies to rethink business models in which products are not simply discarded, but reused or integrated into new products.

Further Applications of the Principle?

The “as a Service” model can be applied far beyond lighting. Similar concepts already exist in other sectors: Furniture-as-a-Service: Companies such as Steelcase offer office furnishings for rent instead of selling them. Printer-as-a-Service: Companies such as Xerox provide printing services where customers pay for printing performance rather than owning the printer itself.

Clothing-as-a-Service: Some fashion companies are experimenting with clothing rental models to make the textile industry more sustainable.

Conclusion

The “Light as a Service” model described in Material Matters impressively demonstrates how companies can operate more sustainably while also achieving greater economic success through circular economy principles. It proves that it is possible to use resources more efficiently, reduce waste, and at the same time create innovative business models that benefit both companies and customers. Buildings as Material Banks (Madaster)

Idea: Viewing Buildings as Raw Material Storage

One of the central problems of the construction industry is that many building materials are not reused after a building is demolished.

Material Matters introduces the concept of material passports, which document the materials used within a building.

This makes it possible to determine exactly which materials can be reused or recycled once the building reaches the end of its life cycle.

Implementation: The Madaster Platform

The company Madaster, co-founded by Thomas Rau, developed a digital platform on which buildings are managed as “material banks.”

Similar to a financial portfolio, Madaster documents the material inventory of a building.

Building owners, architects, and investors can therefore plan long-term strategies for how materials can be reused once a building reaches the end of its life cycle.

The goal is to drastically reduce waste in the construction industry while preserving the economic value of materials.

Example: EDGE Olympic, Amsterdam

The EDGE Olympic office building is one of the first projects to be fully documented using material passports. It contains a precisely listed inventory of materials that can be returned to the material cycle once the building reaches the end of its service life. In this way, a circular value chain is created within the construction industry.

Conclusion: A Change in Thinking Is Necessary

The examples presented in Material Matters show that shifting from a linear “take-make-dispose” model to a circular economy is not only environmentally necessary, but also economically beneficial.

The most important principles of the circular economy are:

Use Instead of Ownership – Products are offered as a service rather than sold.

Durability and Repairability – Companies have an economic interest in creating long-lasting products.

Material Passports and Take-Back Systems – Raw materials remain within the cycle instead of being lost.

New Business Models – Companies benefit from long-term customer relationships instead of one-time sales.

Many companies are already implementing such concepts, but genuine transformation will also require political frameworks and a shift in societal thinking.

Interesting Facts About Ceilings and Sustainability

Is Wood Sustainable If 30–60% of Harvested Timber Is Burned Immediately?

Facts About CO₂ and Construction Timber

The carbon (CO₂) stored in trees can be released or stored in different ways after timber harvesting. The distribution of how wood is utilized depends heavily on forestry practices, local markets, and the intended applications of the wood. Typical proportions are as follows:

Construction Timber (Long-Term Storage):

A relatively large share of harvested wood is used for long-lasting products such as structural timber or furniture. These products can store carbon for decades or even centuries. On average, around 20–40% of harvested wood ends up in durable products such as construction timber.

Burned Wood (Short-Term Release):

Part of the wood, especially waste products such as branches, bark, or low-grade timber, is either burned directly or used as biomass in energy facilities. This share can release CO₂ again within a year or relatively quickly. Exact figures vary, but often 30–60% of harvested wood is processed into biomass or burned, releasing its carbon within a short period of time.

Another portion of the wood may be used in short-lived products that are disposed of after only a few years. The exact percentages depend strongly on the region, wood species, and end use.

To calculate the carbon content of wood and the amount of CO₂ released during combustion, several general assumptions and typical values are helpful.

Assumptions and Typical Values:

- Dry biomass consists of approximately 50% carbon.
- 1 cubic meter of construction timber (dry weight) contains approximately 250–450 kg of carbon (depending on the wood species, e.g. spruce approx. 250 kg, oak approx. 450 kg).
- When wood is burned, carbon (C) reacts with oxygen (O₂) to form CO₂. The mass ratio of CO₂ to carbon is approximately 3.67 (because CO₂ consists of one carbon atom and two oxygen atoms).

Calculation Steps:

Carbon Mass in Construction Timber

For 10 cubic meters of construction timber, it can be assumed that approximately 2,500–4,500 kg of dry timber are present (depending on the wood species).

Of this, approximately 1,250–2,250 kg would consist of carbon.

Amount of CO₂ Released from Burning Timber Waste

Around 30–60% of a tree may become waste during the production of construction timber and may subsequently be burned as energy wood or biomass. This depends on the type of sawing process and the efficiency of timber processing.

Assuming that 50% of the timber volume becomes waste and is burned:

CO₂ Emissions from Combustion

If half of the 1,250–2,250 kg of carbon contained in the timber is burned as waste wood, this would correspond to 625–1,125 kg of carbon.

Multiplying this carbon amount by the factor 3.67 (conversion from C to CO₂) results in CO₂ emissions of approximately 2,293–4,128 kg of CO₂.

Conclusion

When the waste products from 10 cubic meters of construction timber are burned, approximately 2.3 to 4.1 tons of CO₂ are released.

What Does ESG Stand for in the Construction Industry?

ESG stands for Environmental, Social, and Governance and is becoming increasingly important in the construction industry because it evaluates companies and projects according to criteria that go beyond purely financial aspects. Below is an overview of how ESG is relevant in construction and why it matters.

Environmental

This aspect focuses on the environmental sustainability of construction projects. It concerns how buildings and construction processes can minimize environmental impact:

- Resource efficiency: Reducing energy consumption, using renewable energy sources, and minimizing water usage.
- Materials: Use of sustainable, recyclable, and non-toxic materials.
- Waste management: Reducing construction waste and implementing recycling processes.
- Carbon footprint: Minimizing emissions generated through the construction and operation of buildings, such as transportation and on-site construction activities.

Importance:

Since the construction sector contributes significantly to global CO₂ emissions, reducing environmental impact is essential in order to combat climate change and comply with increasingly strict regulations.

Social

The social aspect relates to how construction projects contribute to society and how social impacts are measured and considered:

- Health and safety: Ensuring safe working conditions on construction sites.
- Quality of life: Designing buildings that improve the well-being of occupants, for example through healthy indoor climates, ventilation, and daylight access.
- Communities: Considering the impact on local communities, supporting local employment markets, and promoting social inclusion.

Importance:

A positive social impact can strengthen trust within communities and increase acceptance of construction projects. In addition, safe and sustainable buildings can improve the quality of life for users.

Governance

This aspect covers how companies in the construction industry are managed and governed:

- Ethical business practices: Transparent and fair business practices, including anti-corruption measures.
- Compliance: Adherence to all legal regulations, especially regarding environmental and safety standards.
- Sustainable supply chains: Taking responsibility for the sustainability of suppliers and subcontractors.

Importance:

Good corporate governance helps minimize risks, ensure regulatory compliance, and build trust among investors and the public.

Importance of ESG in the Construction Industry

- Long-term value: Projects that meet ESG criteria are often more sustainable and profitable in the long term because they face fewer risks related to environmental damage, legal disputes, or social conflicts.
- Regulatory requirements: Governments and financial institutions are increasingly emphasizing ESG standards. Investors are paying closer attention to how ESG criteria are implemented in companies and projects.
- Market positioning: Companies that comply with ESG criteria can position themselves as responsible market leaders and gain competitive advantages.

Overall, ESG in the construction industry offers not only environmental and social benefits, but also economic incentives, as sustainable buildings can reduce operating costs, increase property value, and attract investors.

Interesting Facts About Ceilings and Sustainability

Sustainability – When Is a Building Renovation Taxonomy-Compliant?

The EU Taxonomy is a classification system that defines sustainable economic activities in order to direct investments toward environmentally friendly projects. For building renovations, specific criteria have been established to determine when an investment can be considered taxonomy-compliant. These criteria are primarily based on reducing energy consumption and improving the energy efficiency of buildings.

Requirements for Taxonomy Compliance in Building Renovation:

1. Improvement of Energy Efficiency

A renovation is taxonomy-compliant if it leads to a significant improvement in the building's energy efficiency. Specifically, this means: **At Least 30% Energy Savings:** An energy-related renovation must achieve at least a 30% reduction in primary energy demand (measured in kWh/m² per year). This is the minimum criterion for classifying a renovation as sustainable.

2. Compliance with EU Regulations

The renovation must comply with the requirements of the EU Energy Performance of Buildings Directive (EPBD). In most member states, this means that the renovation should significantly improve the building's energy efficiency class.

Specific national regulations implementing the EPBD must also be considered, as these may vary from country to country.

3. Technical Screening Criteria of the EU Taxonomy

For building renovations, the EU Taxonomy Regulation defines technical screening criteria that include:

No Significant Harm to Other Environmental Objectives: The renovation must not negatively impact other EU Taxonomy environmental goals, such as the circular economy, water management, or pollution prevention.

Climate Change Adaptation: Investments in building renovation must also include measures for climate adaptation to ensure the building is resilient to the impacts of climate change.

4. Sustainability in Renovation

The construction materials and technologies used must also meet sustainability principles:

Use of Environmentally Friendly Materials: Materials should be resource-efficient, recyclable, and sustainably sourced.

Minimization of Waste: Measures should be taken to avoid and recycle construction waste.

5. Reporting and Transparency

Companies must transparently disclose in their sustainability reports how their investments fulfill the above criteria. This includes documentation of the measures implemented, the achieved energy savings, and the materials used.

Key Values and Indicators

- **Primary Energy Consumption (kWh/m² per year):** The most important indicator of a building's energy efficiency. A reduction of at least 30% is required for taxonomy compliance.
- **CO₂ Emissions (kg CO₂/m² per year):** Indirectly linked to energy savings, the renovation should lead to a significant reduction in CO₂ emissions.
- **Energy Efficiency Classes:** Improvement of the building's energy efficiency class according to national standards.

Conclusion

In order for a renovation investment to be classified as taxonomy-compliant, it must achieve at least a 30% reduction in energy consumption, comply with EU building directives, avoid harming other environmental objectives, and be carried out in line with sustainability and transparency principles. The goal is to reduce the building's carbon footprint and prepare it for future climate-related challenges.

Requirements for Taxonomy Compliance in New Construction Projects:

1. Energy Efficiency Requirements

Energy Efficiency Class A: A new building must achieve at least the highest energy efficiency class (usually Class A) as defined by national legislation. In most cases, this corresponds to very low energy consumption and the use of efficient, modern technologies such as heat pumps or passive house design.

Low Primary Energy Demand: The building's primary energy demand (PED) must be at least 10% below the national requirements for Nearly Zero-Energy Buildings (NZEB). NZEB already represents a highly demanding energy standard required for all new buildings under the EU Energy Performance of Buildings Directive (EPBD).

Example: If national regulations define an upper limit of 100 kWh/m² per year for an NZEB, a taxonomy-compliant building would need to achieve a maximum consumption of 90 kWh/m² per year.

2. CO₂ Emissions and Climate-Neutral Construction

New buildings should be designed to minimize CO₂ emissions. This includes both direct emissions (e.g. from on-site energy generation) and indirect emissions (e.g. from building operation and energy supply).

The use of renewable energy sources (e.g. solar energy, geothermal systems, or photovoltaics) is essential to ensure climate-friendly energy supply.

3. Climate Change Adaptation

The building must be resilient to the impacts of climate change. This means it should be prepared for both extreme weather events (e.g. heavy rainfall or heatwaves) and long-term climatic changes.

Measures for climate adaptation may include improved thermal insulation, robust façade and roof constructions, as well as efficient water management systems (e.g. rainwater harvesting).

4. Sustainable Materials

The materials used in construction must be environmentally friendly and sustainable. This includes:

Recyclable Materials: The use of materials with a low environmental footprint that can be recycled at the end of their service life.

Avoidance of Environmentally and Health-Hazardous Substances: Materials containing environmentally harmful or hazardous substances should be avoided.

5. Circular Construction Economy

New buildings should follow the principles of the circular economy, meaning that resources and materials are used and reused as efficiently as possible. This includes:

Minimization of Construction Waste: Measures to prevent and recycle construction waste are required.

Design for Deconstruction: Buildings should be designed so that materials can be easily dismantled and reused at the end of the building's life cycle.

6. Water Efficiency

A new building should integrate technologies and systems that reduce water consumption.

7. No Significant Harm to Other Environmental Objectives

The new construction investment must not have significant negative impacts on other environmental objectives of the EU Taxonomy, such as:

Prevention of Pollution: Avoiding pollution of air, water, or soil.

Preservation of Biodiversity: New buildings must not negatively affect local biodiversity and should not be constructed on environmentally sensitive land.

8. Reporting and Transparency

The taxonomy-compliant criteria must be transparently documented and disclosed in reports. This includes evidence regarding energy consumption, materials used, and the building's CO₂ balance.

Key Indicators and Threshold Values:

- **Primary Energy Demand (kWh/m² per year)** must be at least 10% below national NZEB requirements.
- **Energy Efficiency Class:** New buildings must achieve the highest energy efficiency class (usually Class A).
- **CO₂ Emissions (kg CO₂/m² per year):** Reduction of CO₂ emissions is indirectly measured through energy demand and the use of renewable energy sources.

Conclusion

A new building is considered taxonomy-compliant if it meets very high energy efficiency standards (at least 10% below NZEB requirements), relies on low-carbon or climate-neutral technologies, is adapted to climate change, and uses sustainable materials. Furthermore, construction activities must not significantly harm other EU environmental objectives, and all investments must be transparently documented.

Genuine Re-Use

from Signa Vienna to the Fural company restaurant in Gmunden

In the spirit of sustainable construction, Fural decided to equip its new office with a high-quality pre-owned company kitchen from Signa. Instead of purchasing or producing new furniture, we follow the re-use principle — the reuse of products that are still in excellent condition and of high quality.



Signa Vienna



Signa Vienna

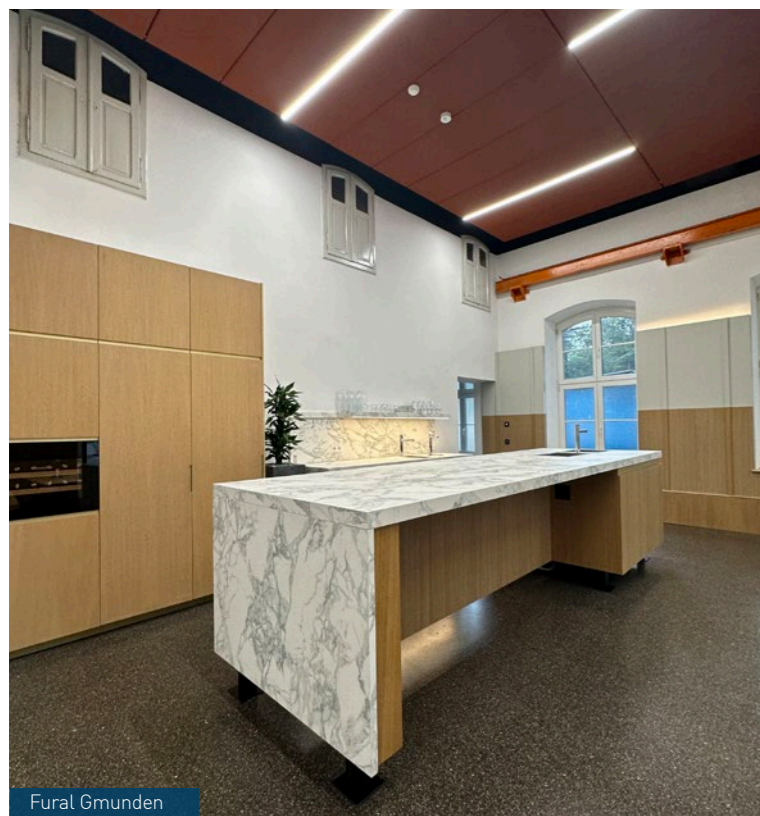

Fural Gmunden

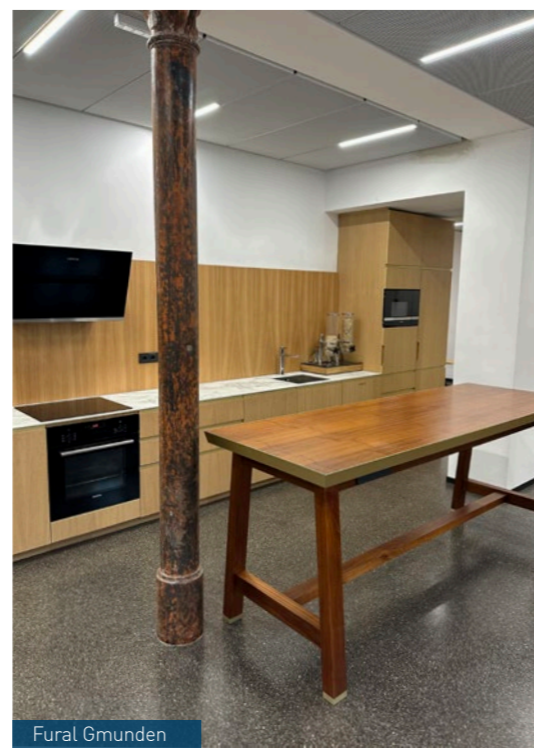

Fural Gmunden



Fural Gmunden

Genuine Re-Use

Further Examples of Resource Conservation and Re-use — Re-use Using the Example of the Fural F1 Office in Gmunden

1. Company restaurant from Signa with champagne cooler
2. Glass partition walls from VIAG Intercom Munich
3. Company restaurant from Signa with retractable screen
4. Re-used office cabinets
5. Re-used tool safe from Signa Vienna
6. Reuse of the meeting room from the former office
7. Gaming room with furniture from Signa Vienna

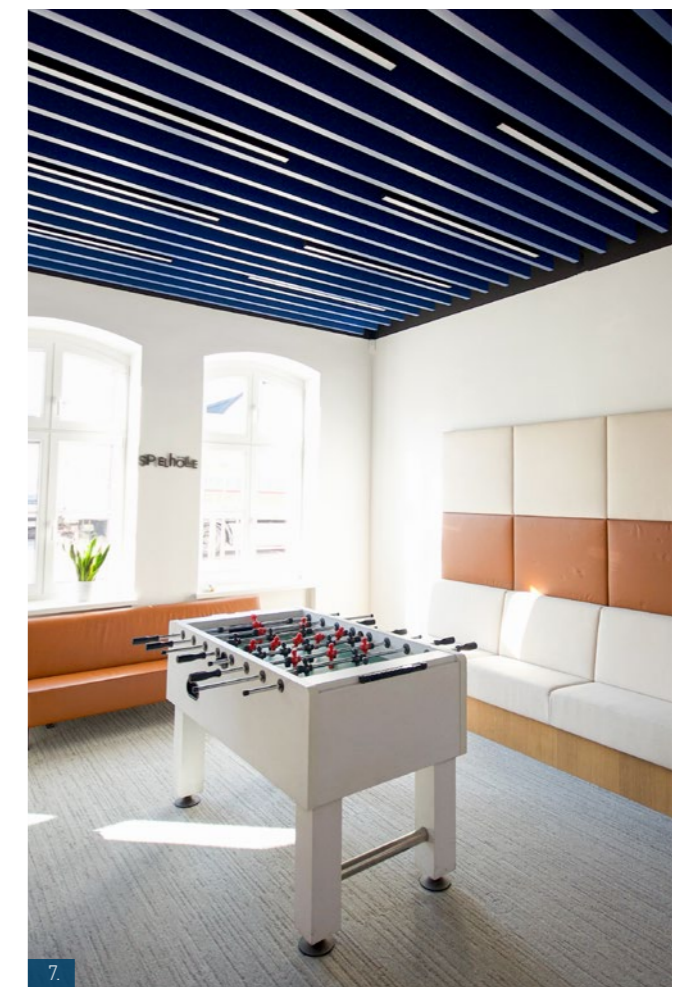
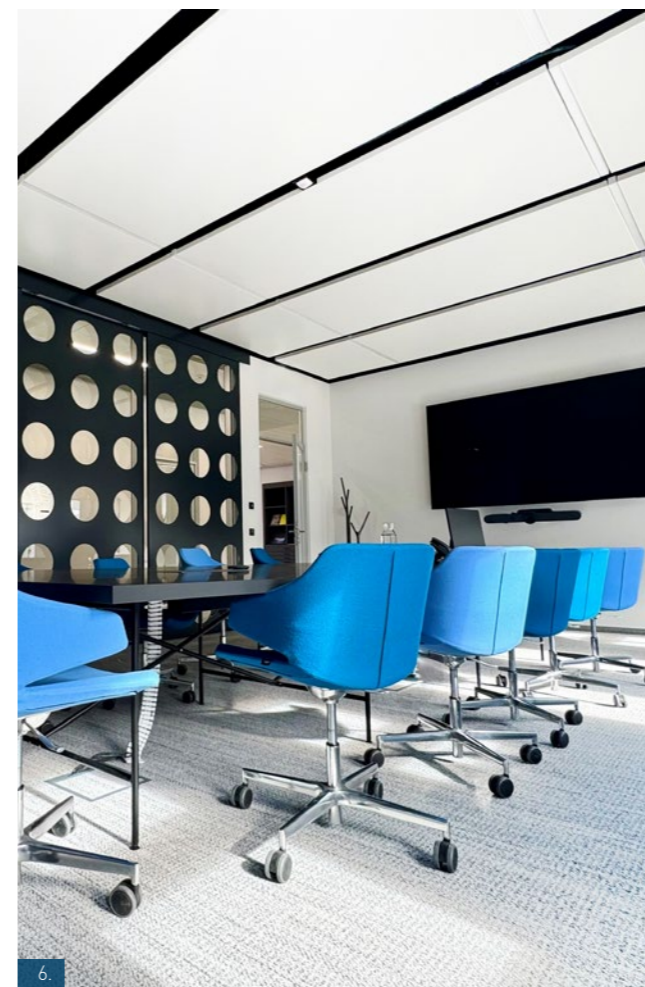
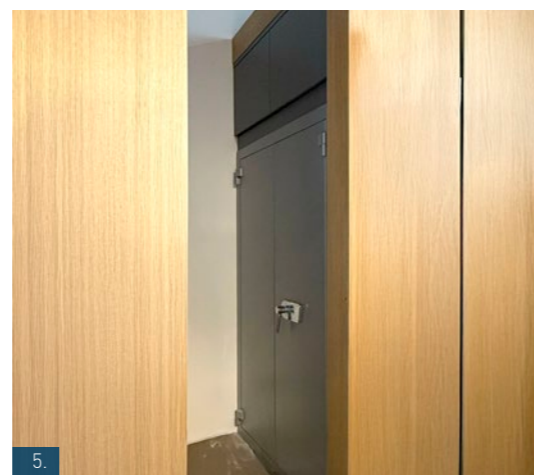
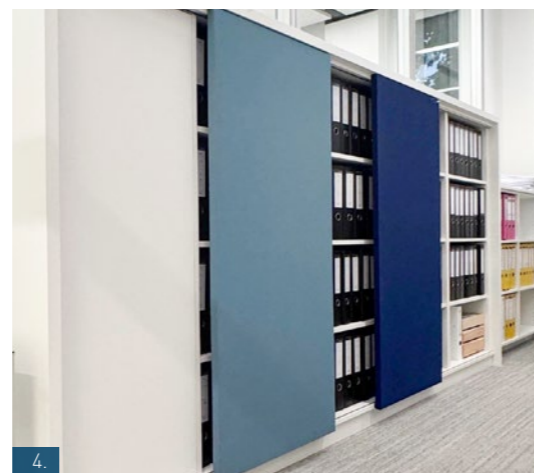
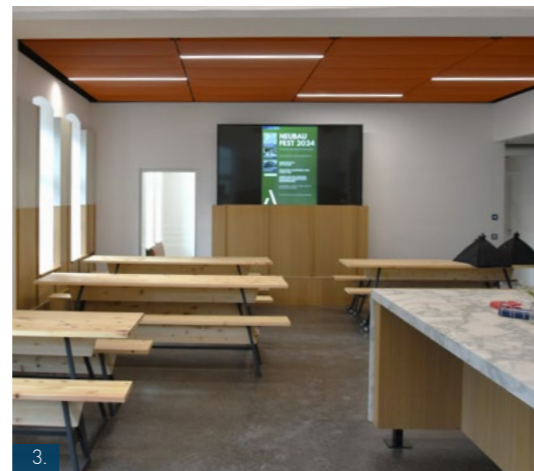
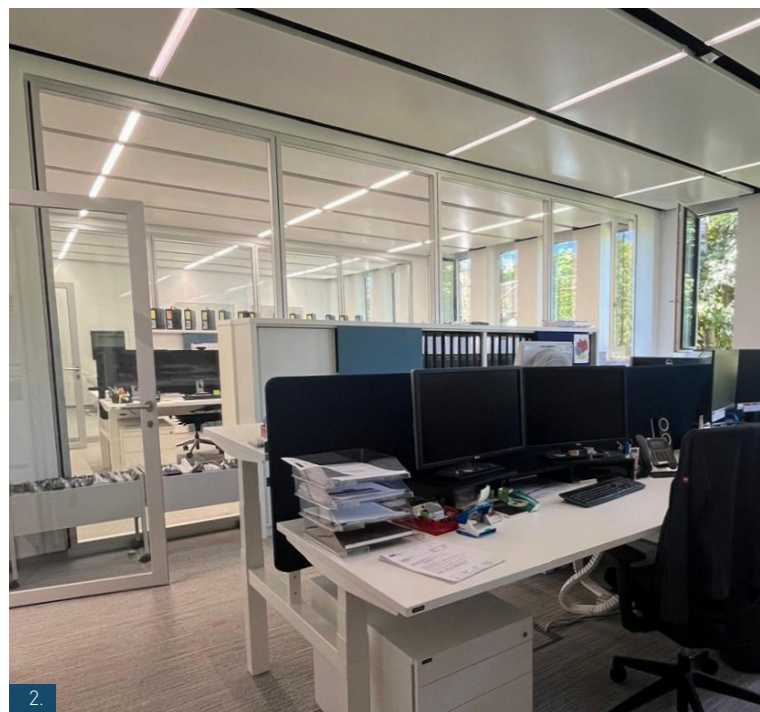

Genuine Re-Use

...or, at the right time,
the right contacts.

The starting point was a general exchange between ATP's Nuremberg office and Fural on the topic of sustainability and its significance in relation to metal ceilings. Various emails and phone calls were followed by a meeting in Nuremberg. In addition to discussing the material cycle of metal ceilings, potential re-use solutions were also explored. During the conversation, a concrete demand emerged. However, there is currently no existing stock of re-use material available.

As part of renovation and partial demolition works at the Fural site in Gmunden, suitable materials actually became available. Photos of the existing ceilings were exchanged quickly, and the available quantities were coordinated — sometimes it is best to simply make things happen.

The ceiling panels recovered from the dismantling process were sent to the new construction site, where they were stored until reinstallation. The required substructure was also ordered and installed.

Anyone who does not know the background would never realize that these are "used" ceiling panels...

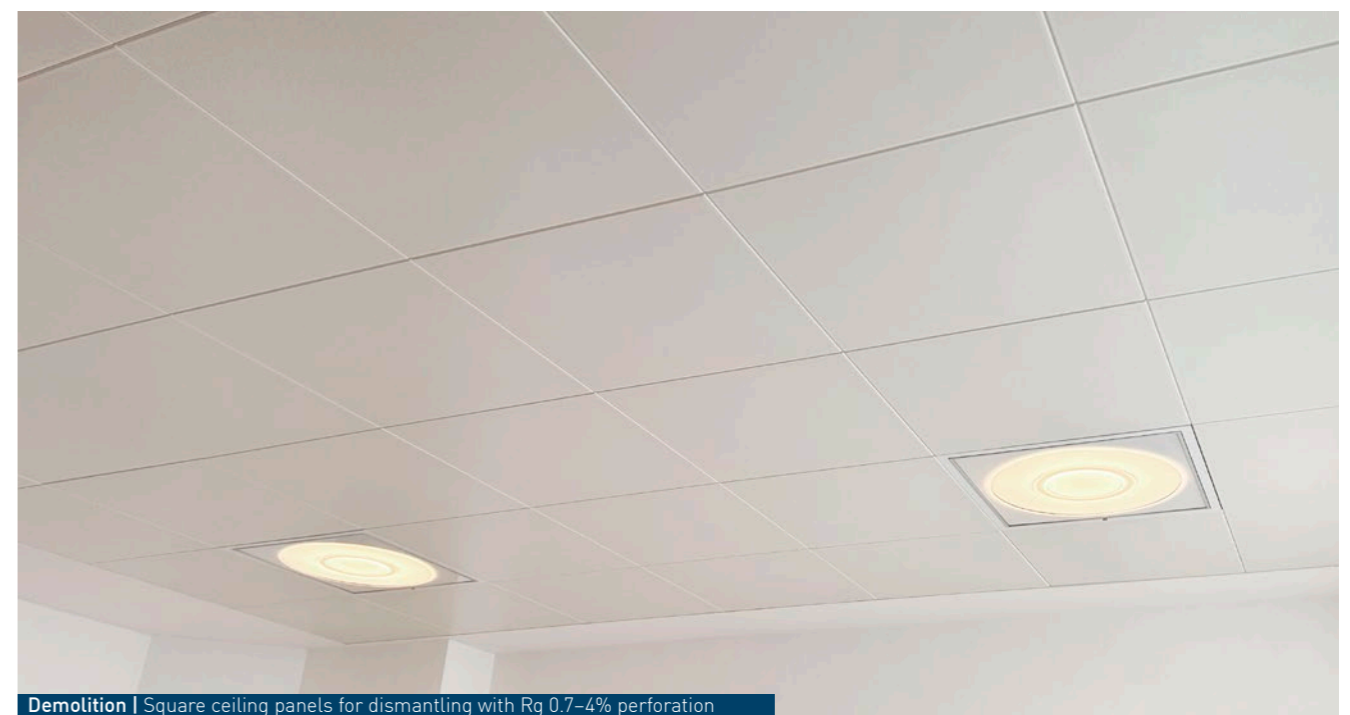
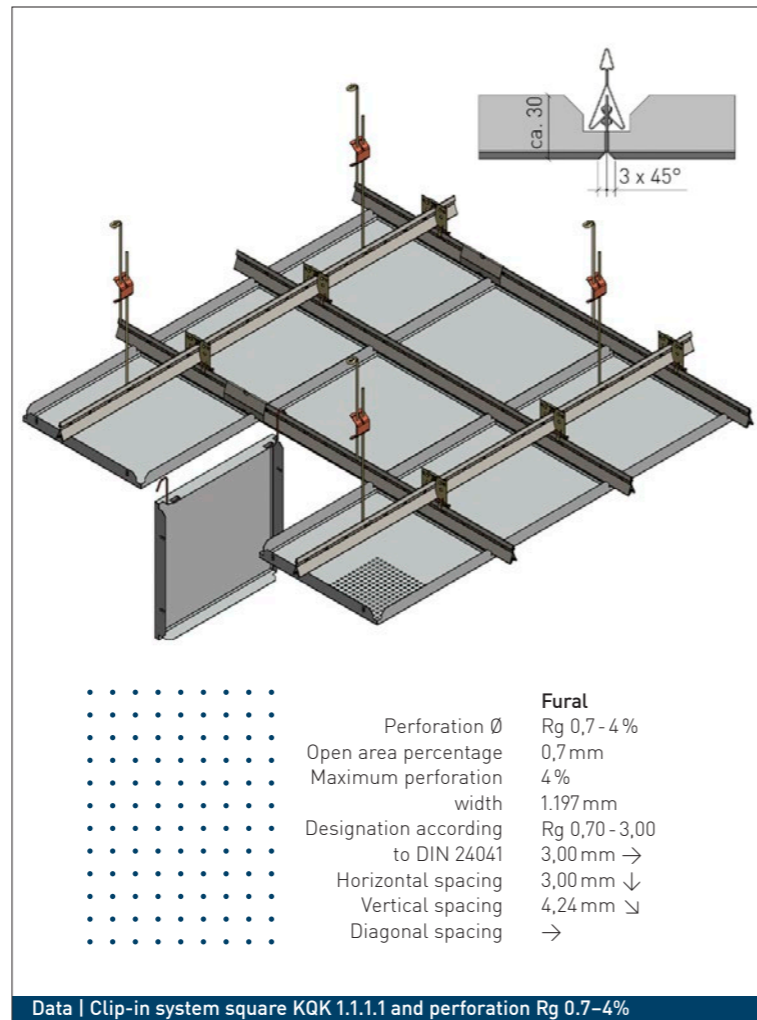

The client, ABF Pharmacy, was immediately enthusiastic about the idea. The building owner had already placed great importance on sustainability throughout the project. What surprised us, however, was that all three contractors approached were willing to submit a quotation without any hesitation. You cannot tell that the metal ceiling panels had already been installed elsewhere before — they look as good as new. In the future, we will continue to use reclaimed building materials whenever possible.

The reuse of the ceiling panels is a sensible approach; however, the installation process revealed an increased workload due to sorting and necessary adjustments. With clearer preliminary inspections and better coordinated logistics, future implementations can be carried out far more efficiently.

The architect gave us the option of installing used metal ceiling panels. No one in our company had any concerns about this. On the contrary, we believe it was a positive decision and that we contributed to the circular economy in construction. In addition, we were able to save costs.

Jürgen Klieber,
Dipl.-Ing. (FH) Architect
ATP Nürnberg Planungs GmbH



Christian Kempe,
Technical Director
Merkel Trockenbau GmbH



Jochen & Eva Schreier
Building Owner and
Landlord,
Pharmacist and Tenant



Genuine Re-Use

Planning and Reassembly
New Sterile Laboratory Construction for ABF Pharmacy in Fürth



Planning | Ceiling plan, designed by ATP architects engineers



Reinstallation | Installation of ceiling panels in the room



Reinstallation | Delivery of the ceiling elements to the construction site

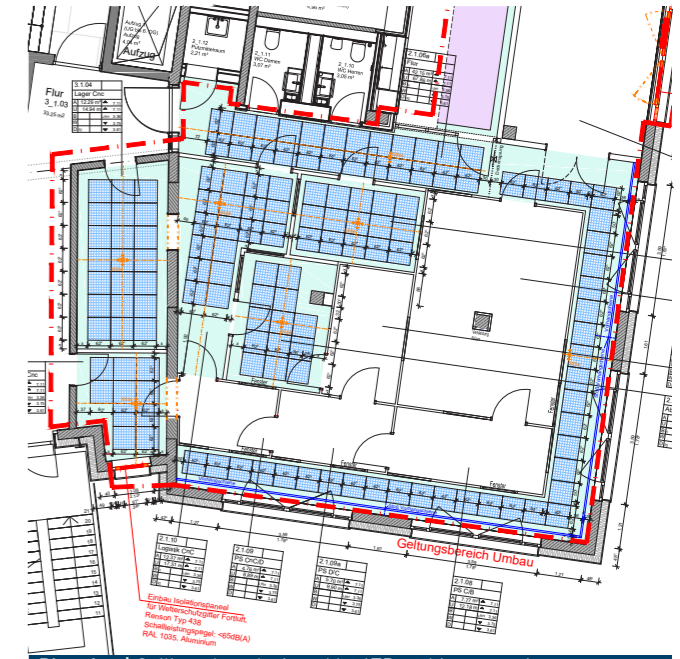

Planning | Ceiling plan, designed by ATP architects engineers



Reinstallation | Corridor without ceiling panels

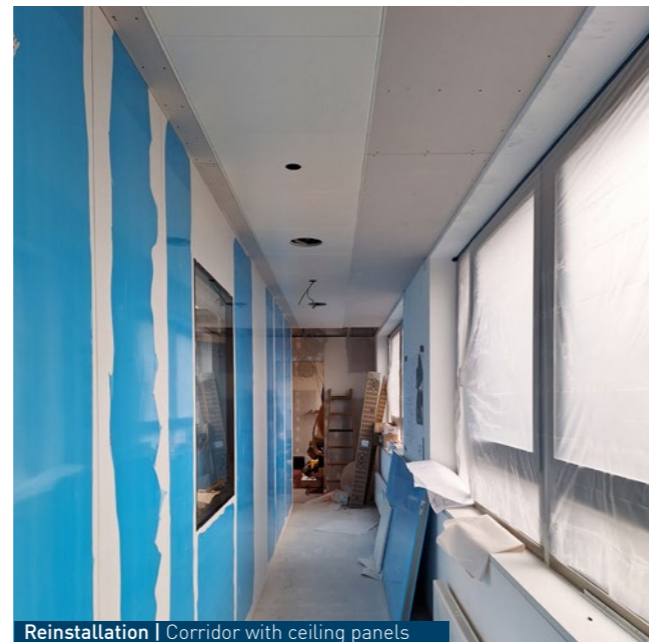

Reinstallation | Corridor with ceiling panels



Reinstallation | Installed ceiling panels in the corridor

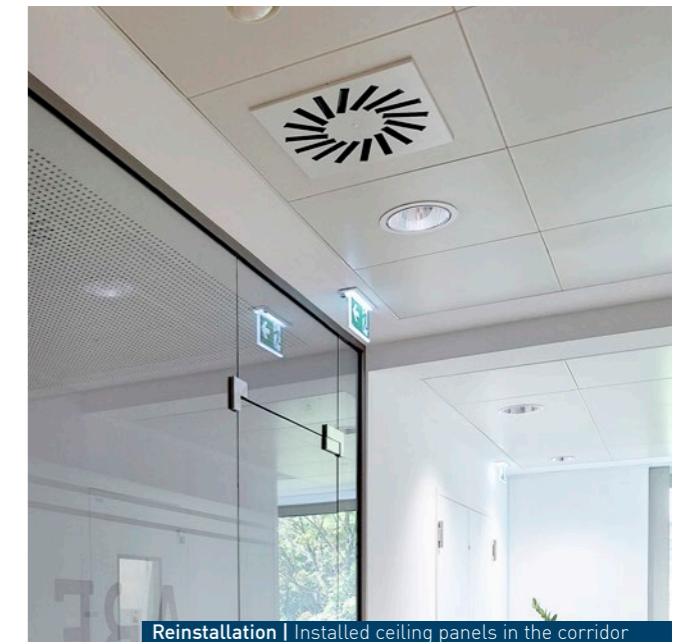

Reinstallation | Installed ceiling panels in the corridor

	Imprint
Publisher	Fural Systems in Metal GmbH Cumberlandstraße 66 4810 Gmunden Austria
Date	March 2026
Photos	Stauss Processform GmbH (pages 9, 12, 32) Fural's own images (cover page, pages 3, 4, 5, 6, 7, 13, 39, 52, 53, 54, 55, 56, 57) Signa Archive (pages 4, 52) To Kuehne (page 8) Photo-Graphics Hilinger-Perfahl OG (page 8) Emmi (pages 8, 22, 23) GOTECH (pages 8, 14, 15) Timo Schwach (pages 9, 12) Dirk Wetzl (page 9) Bruno Klomfar (pages 9, 12) Cosmin Dragomir (page 12) Hennie Raaijmakers (page 12) Lucas van der Wee (page 13) Werner Huthmacher (page 13) Gerencia Madrit (page 13) Roman Boensch (page 13) Dieter Hawlan (pages 15, 17, 19, 21, 23, 25, 27, 29) Robert Halbe (pages 16, 17) A.S.R. Utrecht (pages 18, 19) Jansen Service Center (pages 20, 21) Adam Mørk (pages 24, 25) Kaefer (pages 26, 27) Ludwigshafen Heart Center (pages 28, 29) Schelke Bonnetsmueller (page 32) Archive of the former pinta acoustic GmbH (pages 33, 34, 35) Janine Kyofsky (page 39) Fural Yearbook 2024 (page 40) Fural Sustainability Report 2024 (pages 42–45) ATP architects engineers (pages 56, 58, 59) Merkel Trockenbau GmbH (page 56) Photo by Jochen and Eva Schreier (page 56)
Concept and Design	Marketing Team
Paper	MagnoVolume 250 g/m ² and 130 g/m ² (PEFC/06–39–16)
Texts	Fural Marketing
Typeface	DIN Pro Light and Medium
Printing	Friedrich Druck & Medien GmbH Zamenhofstraße 43–45 4020 Linz Austria
	confirms the compensation of greenhouse gas emissions through additional climate protection projects.



TAIM

Fural

Systeme in Metall GmbH
Cumberlandstraße 66
4810 Gmunden
Austria

T +43 7612 74 851 0
E fural@fural.at
W fural.com

Metalit

AG
Murmattenstrasse 7
6233 Büron
Switzerland

T +41 41 925 60 22
E metalit@metalit.ch
W metalit.ch

Dipling

Werk GmbH
Königsberger Straße 21
35410 Frankfurt Hungen
Germany

T +49 6402 52 58 0
E dipling@dipling.de
W dipling.de

BST Brünsch

GmbH
Alter Fuhrweg 10
57223 Kreuztal
Germany

T +49 2732 55 89 90
E bruensch@bruensch.com
W bruensch.com

Fural

Bohemia s.r.o.
Průmyslová II/985
383 01 Prachatice
Czech Republic

T +420 732 578 739
E info@fural.cz
W fural.com

Fural

Systeme in Metall GmbH
Büro BeNeLux
Corluytstraat 5 GLV
2160 Wommelgem
Belgium

T +32 3 808 53 20
E benelux-france@fural.com
W fural.com

Fural

Systeme in Metall GmbH Sp. z o.o.
Oddział w Polsce
ul. Krakowska 25
43-190 Mikołów
Poland

T +48 32 797 70 64
E polska@fural.com
W fural.com

Sales locations

Production locations

- AT Gmunden
- CH Büron
- DE Frankfurt Hungen
- DE Kreuztal
- CZ Prachatice

Technical locations

- AT Gmunden
- CH Büron
- DE Frankfurt Hungen
- DE Kreuztal
- BE Wommelgem
- PL Mikołów
- FR Paris
- CZ Prachatice

**360 EMPLOYEES
7 LOCATIONS
4 BRANDS**

HEALTH

OFFICE

EDUCATION

MOBILITY